

Aether-Physics and -Philosophy

Ninth Part

09.	Aether- Electric- Technics	Update 2011-12-12	Page
09.01.	Introduction and Objectives	Electromagnetism by view of the aether, free energy, disclaimer	1
09.02.	Aether Characteristics	Properties of that real substance, Free and Bound Aether, swinging, stroke, pressure and flow	4
09.03.	Relevant Appearances	Photon, electron, atom, molecule, aura, membranes	9
09.04.	Charge	static / dynamic, positive / negative, plus / minus, source / sink, earth / atmosphere, lightning	17
09.05.	Current	DC / AC, conductor / isolator, direction of current, stroke, electric / magnetic field	22
09.06.	Magnets	Earthly magnetic field, permanent magnets, attraction /rejection, electric / magnetic field	28
09.07.	Magnet and Current	Lorentz-force, induction, DC-generator / -motor, new charge-generator	33
09.08.	Unipolar-Generator	Faraday-generator, induction-laws and violation, energy-constant and violation, effective current-generator	39
09.09.	Railgun- and Ballbearing-Effects	Cause of unusual acceleration, 'heated-up' aether-swinging	44
	ap09ae.pdf	Print version of previous chapters	
		Diverse chapters will follow	

09.01. Introduction and Objectives

Nikola Tesla

Civilization in today's standard could not exist without electricity. Without Nikola Tesla (1856 - 1943) merely would exist that electrical technology because also today practically all units are based on his experiments and patents. Correctly he is called the most important inventor-genius of modern times. Strange enough this is not commonly known. At its best, one knows somehow a physical 'Tesla-unit' or a 'Tesla-coil' or a proud man sitting calmly within sparking flashes (see picture 09.01.01 upside). At 'scene of Free Energy' however one well knows his vita and his revolutionary inventions.

Tesla was convinced the atmosphere is full of 'radiations' which could be used by suitable antenna. Tesla often talked about that new kind of energy, which today probably is called 'vacuum-, space- or zeropoint-energy' - and still is not defined exactly. Tesla talked about another kind of electricity and many years he was working on energy-transmission around the globe - and even today the existence and properties of these 'scalar-waves' became not clear. Also many other Tesla-experiments and -patents could not be reproduced up to now. The known electricity, based on Tesla, is well known and functions everywhere. However some of his visions still are not realized.

Most Tesla-documents got 'vanished', so today one only knows his patent-scripts (which as usual do not show decisive parts). At the other hand one knows many facts about his public demonstrations and lectures, however only by concerning press reports. So Nikola Tesla up to now remains a 'mysterious appearance', e.g. also based on statements like this:

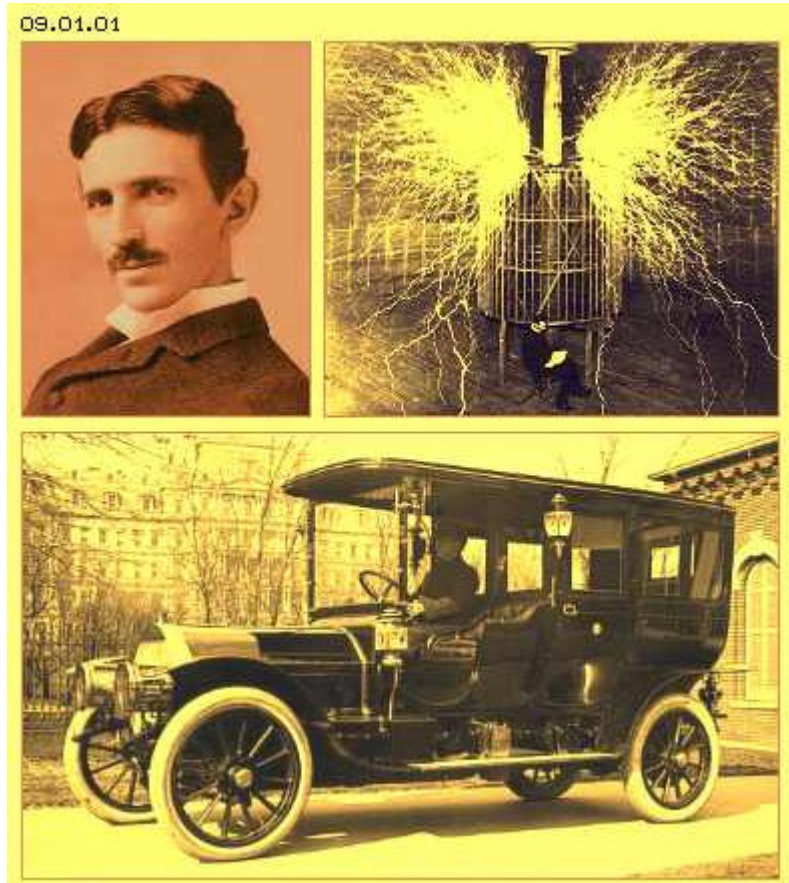

"Already at early times men did realize, all perceptible materia comes from a basic substance, a waver-thin something, which beyond all imagination fills up whole space, the Akasha or light-bearing Aether, onto which is affecting the life-giving Prana or creative Spirit, which by never ending swinging movements brings all things and appearances into existence. That basic substance, by immense speed slinging around in never ending vortices, breeds to solid materia; if the force becomes diminished, the movements calm down and the materia disappears by reconvertng into basic substance ..." Like this, Nikola Tesla stated at many lectures and pointed out future possibilities for using Free Energy, e.g. by his most famous sentence: "Before many generations will pass, our machines will be driven by a force which is free available at every spot of the universe".

So at the one hand, Tesla claimed to be able to download energy from the atmosphere at any location and at any time, by just simple apparatus. So it's not quite obvious, why he worked at problems for transmission of energy to remote locations for years. Also rather strange is Tesla's mystic reference: "This idea is not new, we find the idea at famous myth of Antreus, who draws energy off the earth ...". If you are not familiar with old Greece: Antreus (Antaios, Antaeus) was a son of Gaia (Mother Earth) and Poseidon (God of Seas). That giant urged everybody for a fight and defeated all competitors. Hercules however registered, that Antreus got his power by the earth. So he lifted the giant up in the air and thus conquered the forceless Antreus. Now the question is: where from comes Tesla's 'new energy', from the atmosphere or the earth? Some later we need intensive analyses to find the real source for usable energies.

Auto-Motor

Nikola Tesla was a real genius as he was able to visualize new devices in details. Based on rough sketches the apparatus was build and the machines produced wanted function straightaway. So Tesla had not to find inventions by try-and-error, but he did know exactly the suitable technical solutions all times. Previous mentioned

divergences thus probably came up as he was forced to 'speak with a forked tongue' at least from the year 1930. At this time he did drive an automobile (Pierce-Arrow, see picture 09.01.01 below) with an electric motor by an autonomous power supply. Reliable witnesses reported extended trips with remarkable speed. An autonomous power supply for everybody, practically free of costs, was not acceptable for companies of lucrative energy industry - and they were able to reduce Tesla's activities to 'side issues'.

When Tesla said "... before many generations are passed by, our machines ...", he did talk about his already well-tested and running technology. The performance of that machine was well known by the 'decision-makers'. Tesla was right with his suspicion, it would take some generations until Free Energy would become free for everybody. Many other inventors made similar experiences, as soon as they demonstrated well-working machines. Up to now nothing has changed. At the other hand, current crises result grave changes. Few years later, the global economy will be dominated by China and India. Both countries have no conventional energy resources, however suffocate from environment pollution. So it's really possible, clean and free energy now could become reality.

Free Energy

Today only one autonomous generator is known, serving for power-supply of a religious community at Switzerland since many years. However the mode of functions of that 'Testatika' (picture 09.01.02) still is unknown - hidden by 'ethic reasons'. Probably there are solutions for realizing Free Energy by dozens - as soon as first machines are 'admitted' to the market.

The conceptions of many inventors and researchers are well known at appropriate groups, e.g. by names like Aspden, Bedini, Bearden, Camus, Coler, Gray, Hubbard, Joe, Kelly, Marinov, Meyers, Miller, Moray, Plauston, Tilly and some more. Their devices by parts did run really effective. Opposite to Tesla however, most were produced via try-and-error and / or do not work continuously. Also the Testatika probably is constructed much too complex,

because even the inventor Baumann did not really know the decisive processes. Often just esoteric reasons are mentioned for function of a construction respective one just does not know much about the underlying energy of the 'vacuum'.

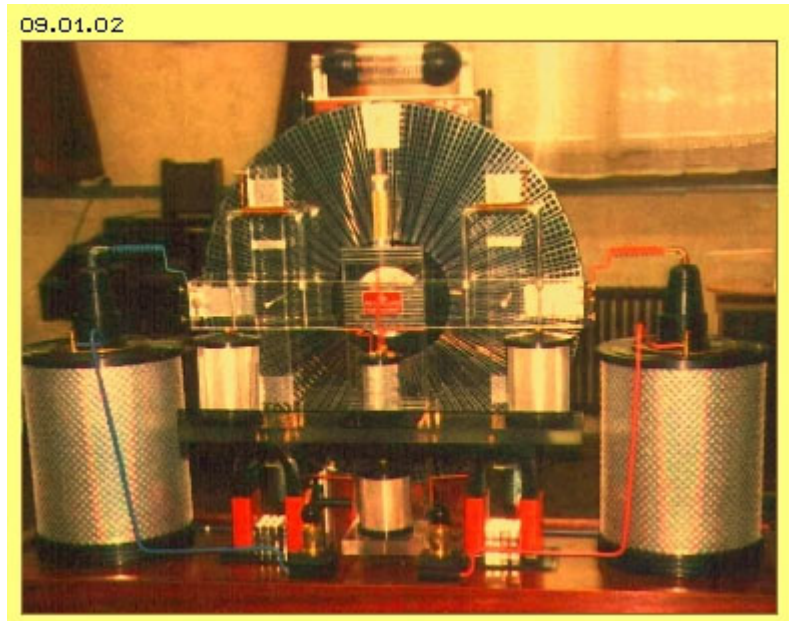

Objectives

With that 'Aether-Electro-Technics' I try to solve that problem, by replacing known abstract models of charge, current, fields, forces etc. by totally concrete motion-pattern of that totally real aether-substance. Thus the effects of already known conceptions of diverse researchers could be logic explained. If the working-effects of the aether are clear or at least the motion-models are somehow reality-conform, devices could be build with improved performance.

The objectives of these chapters are not building such machines - as I am not able to do the most simple experiments by myself. I only can offer pure theoretical new considerations, based on my understanding of the aether. If anybody takes these proposals for experiments or even for building working devices - that's beyond my responsibility and control.

Procedure

The definition and properties of 'my' aether is described in details at earlier chapters, especially at previous part 08. 'Something Moving'. Only some few relevant points of view here are briefly mentioned once more (aether-substance, Free and Bound Aether, swinging, stroke, drift, general aether-pressure). Afterwards, some elementary motion-units are discussed (photon, electron, atom, molecule, aura, membrane).

As new subjects some general electric appearances must be analysed (charge, current, direction of current, DC and AC, earth-electricity, source and sunk). Later on relevant components are discussed (capacitor, coil, transformer, induction, rectifier, magnets, electro-generator and -motor).

At technology of electricity, numberless variations of constructional elements, circuits and devices were build, so one can find merely any stuff quite new. Now here the appearances of electricity are grounded exclusive on

concrete motion-pattern of the aether - and it might happen machines more effective could be constructed, when they are based on that understanding. At any case it should be possible to find plausible explanations for real cause of functions of previous mentioned inventions. Possibly some of these devices could be tuned up - so my vague hopes and objectives.

Unprofessional / scientific

I am quite conscious about the presumption of that undertaking - at the other hand, these problems never were examined really consequent by that sight of real existing aether. I am no nature-scientist and even can not use precise the special terminology. However I define exactly all terms used, mostly divergent to common understanding. For lack of knowledge I well could make 'inventions' and some later I learn, that stuff is known since long. I love that, because for me it's the confirmation, my considerations occasionally happen to be quite right.

I apologize to all readers, that I can not present scientific correct quotes. Today it make much more sense to put any question into search-machines of the web and immediately one will get additional information as you like it. I rarely make quotations, because I always start by common known facts. Afterwards I deduce consequences and describe the conclusions most precise by my own words. For specialists these considerations might be strange or incomprehensible, just because they are quite new - just as only a 'naive layman' can think. At the other hand, some readers will enjoy the process of ideas and first time might find to understand what's going with that strange electricity.

My expositions are unscientific as far as I do not use formula and do not calculate. I can only produce these simple sketches, can design only basic circuit-diagrams and can not develop constructional manuals. So my considerations of the Aether-Electric-Technics are of pure theoretic nature, are only a layman's ideas, however by view of that quite new understanding of the aether - and thus possibly could well create new valuable insights.

Disclaimer

These documents are provided for information purposes only. Should someone build real devices based on information presented here and injure any person or things, I am not liable in any way. Above this, I strongly recommend not to experiment with high voltage circuits, because these are extremely dangerous. I stress once more, I am not liable for any damages, losses or injuries caused by using the information about aether and electric technologies.

Evert / 2011-07-01

09.02. Aether-Characteristics

Dark Cave

Just press the button at the door and the bell inside does its dingaling. Just turn on the switch and the bulb starts shining. Just push the 'gas pedal' and the electric car accelerates. The electric technology functions - nevertheless the real background-processes keep strangely mysterious.

One knows how to combine constructional elements to achieve wanted effects - however what-why-how-is-working mostly remains hidden. One knows well terms like 'mass, inertia, weight, attraction or repulsion etc.' by common handling of parts and particles - however the real cause of these appearances was not detected up to now. Like Platon did show with his famous 'cave-parable' long times ago, we obviously see and know respective handle only 'shadow-figures' - and only occasionally we get an idea what's going on outside the 'dark cave'. We try hard to learn the real background of appearances and events. We possibly could have better success by changing the point of view: at the foreground must exist a real basis resulting seemingly phenomena.

Dark Matter

The problems of cosmology are a good example. At picture 09.02.01 upside left is drawn a sphere and its volume represents the whole universe. Based on appropriate formula one calculates the mass of all known materia, here represented by red sphere M. The forces acting between celestial bodies however show a suitable result only, if twenty times additional 'dark matter' DM is assumed (or additional 'energies' of unknown source and properties).

Expedient would be the assumption, all volume of universe is build by a real existing substance and to call that materia the 'Aether'. The aether is not dark but only invisible for us. It is completely transparent, so marked below left as light-grey face FA. We can directly register only five percent of, at its maximum, which here are represented by the red face GA.

Commonly is assumed, an atom exists by 'nothing' for the most part. Only the elementary particles (electrons, protons, neutrons or their sub-elementary-particles) are assumed to exist really. So as a whole these 'known masses' would represent an even smaller part of the universe. Based on common understanding, nothing can be build of nothing. Total emptiness in general can not exist, no matter that 'vacuum' is empty or only somehow empty. Otherwise all material particles would disperse into ambient space of 'no-thing' immediately. As a substitute, additional fictive prerequisites must be assumed, e.g. like weak and strong atomic forces. These are considered 'naturally really existing', however only because necessary for common atom-models. Realiter one was never able to explain, why and how the atoms should keep together, how that wanted function could be achieved - a typical case of previous 'cave-parable'.

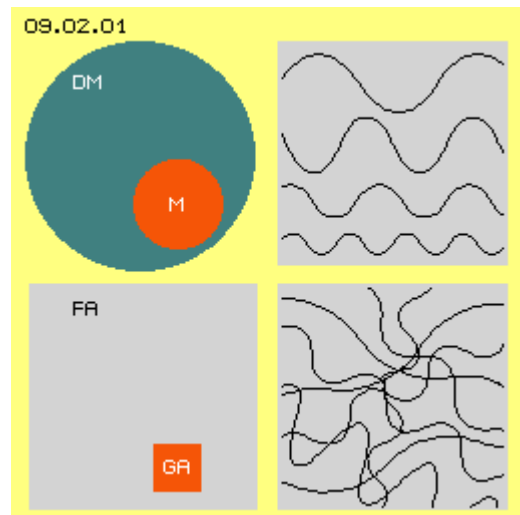

Free and Bound Aether

So it makes sense to assume, whole universe exists by a real substance. The major part is free of known material particle and these regions are called 'Free Aether'. The 'nothing' within atoms naturally is also that real aether. However it does not only 'penetrate' the known materia, but all atoms throughout and exclusive exist by that matter.

Only one sort of aether is necessary to allow all physical appearances. For example, the atoms differ to previous Free Aether only by their internal movement-structures. Such local units build a stabile compound of individual motion-pattern and thus here in general are called 'Bound Aether'. Like mentioned upside, only maximum five percent of all volume of the universe is in shape of Bound Aether (GA, red) and - beside others - 'manifests the material particles'. The remaining major volumes (outside at space and naturally also between atoms) is Free Aether (FA, light-grey).

Radiation and chaotic Motion

At the inter-galactic regions far outside of space, merely exist 'material particles', nevertheless these rooms are not calm. Numberless radiations of different kind are running through the aether, like upside right at this picture simplistic is marked by diverse wave-shaped curves. The 'electromagnetic waves' come from all directions, like below right simplistic is represented by some curves within that face.

Radiation demands no medium, by common understanding, because it's running also through vacuum. Radiation is assumed to be any kind of motion, however a 'moving nothing' can not exist. Finally if one assumes whole space is filled up by the aether, logical results each radiation is a certain motion of the aether.

All radiations can mutually overlay. At each spot outside there within Free Aether, thus swinging movements of all kind are overlaying. The aether is pulled to-and-fro continuously into all three directions of space. This 'jumbled mixture' results just chaotic seeming knots of motions, where every 'aetherpoint' is moving at only short sections of track, swirling around as a cluster of motions within relative narrow space. Nevertheless it's possible to filter a certain frequency out of that chaotic mash, by relative simple devices - e.g. by the 'mysterious' function of a radio-receivers.

Speed, Density, Energy-Constant

Free electrons within a conductor are moving forward less than 1 mm/s. The sound within the air progresses about 330 m/s, thus at least 300000 times faster. The light-speed with its 300000 km/s moves faster again by factor 1000000. Photons are racing though Free Aether with that crazy speed, no matter their movements are crossing practically everywhere.

The sound is a motion-pattern within the air. In principle the pressure-front is a compression, followed by immediate decompression. Only that motion-structure is moving forward within space, each air-particle is only swinging some forward and back again, in principle however keeping its location.

The sound-movement is forwarded from particle to particle, with different speeds depending on the density of the medium. In addition, at each 'elastic push' between particles, a part of the kinetic energy is lost (finally into the 'nothing' of common understanding). The sound spreads aside and becomes weaker and weaker - because the transport is bound to material particles.

As now the photon-movement is forwarded through the aether by unchanged speed for years, the medium must show corresponding higher density. If the light merely loses intensity at that long way, it can not be transported via elastic push from one aether-particle to the next. Analogue to previous sound, the kinetic energy finally would get lost into that 'nothing' (the gaps between particles of the medium). So it's stringent logic conclusion: the aether can not be build by separated particles, but must be a gapless whole.

At first sight this might seem impossible. As the aether is the unique real existing substance, it well can show that 'unusual' materia-property. The aether as basis of all physical appearances compelling must be that continuum, because only within that medium kinetic energy never can get lost. The energy-constant is superior nature-law, otherwise the universe would have died the cold-death since long. All motions of particles inevitably result friction-respective heat-losses. Thus the real background of all appearances can only be a part-less medium.

Impossible

It's the job of our brain to guarantee survival within the material world. For fast decisions it's important to build fix categories, e.g. 'useful / negligible / dangerous'. We feel save only at stable ground and we handle solid tool and mostly solid (constructional-) parts - and these have no inner motion. Thus also within gapless solid aether no internal movements are possible - the instinctive first statement sounds respective our brain immediately judges.

Tesla's idea of a "waver-thin basic substance which swirls around by immense speed at never ending vortices" is much more plausible. Strange enough only Einstein explicit stated in later years, the "inevitable existing aether can not again be build by ponderable particles". However he was not able to draw the consequences of that gapless 'aether-plasma' (and up to now the RT-protagonists refuse to take notice of these later statements of mature Einstein).

Indeed, the motion possibilities within that gapless aether are essentially reduced. Because there are no aether-particles, I call a certain spot within the aether an 'aether-point'. At picture 09.02.02 upside left at A some blue points are marked, which are 'stationary' (like Free Aether is trembling only within a narrow range).

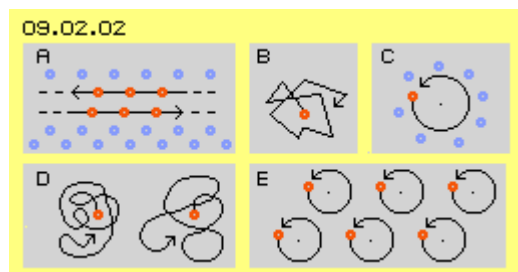

At the second row are marked some red points, which are moving towards left. Such linear motions are not possible, because left side of the aetherpoint no empty space is available. All aetherpoints left side should have to move further left, through whole universe. Also all aetherpoints of right side should have to follow, because within that aether no gaps can come up. At third row some points are moving towards right. This is also not admitted, in general no parts can shift relative to each other within that coherent medium.

Upside was mentioned the Free Aether is steady 'trembling'. At B a track of straight motions is sketched - however the aether can never move like this. The 'aether-mass' is inert and because each movement of an aether-points involves all neighbours, such abrupt decelerations and accelerations into other directions can not exist (and also the inertia of all 'material masses' is based on this background).

Likely impossible are rotating movements (e.g. like a mechanic wheel is turning around its axis). At C a red point is moving at circled track and outside of some blue points are stationary. Within the aether by itself, never can come up such 'scissors-motions' and never some parts or areas can scrape alongside each other.

Swinging in many Variations

At this picture at D left side a motion is sketched, resulting of many short circle-sections (realiter into all three dimensions same time). Like this, one can imagine the 'chaotic' swinging at narrow space of the Free Aether (which however will move all times at 'round' tracks, thus never edged like sketched at B). Naturally at a place the aetherpoints can swing more calm at some longer stretched sections, like marked at D right side. The aetherpoints with such tracks are steady 'trembling', nevertheless the aetherpoints of Free Aether are named to be 'stationary'.

An important limitation is sketched at E. There are drawn six red, narrow neighbouring points. Simplistic the tracks are assumed to be circles. All neighbouring points within gapless aether in principle must keep constant distances all times. If one point is moving at circle track, all neighbours must behave synchronous, thus must swing at corresponding circle tracks.

A 'rotation' occurs, if a point or some neighbouring points are moving around a common fulcrum (see upside right at C). Strictly opposite, within the aether only 'swinging' is possible, where each point is turning around its own fulcrum and all neighbours are moving parallel to. That motion-pattern thus corresponds to a 'sander'. A point left side from centre keeps left all times, a point right side all times keeps right, below remains below, upside point is all times positioned upside of centre. Thus a whole face of aether is 'wobbling' likely. At this animation both shapes of motions are visualized: left side shows the rotation and right side shows the swinging motion (of these six aetherpoints and same time all neighbours at the black connecting lines and also all aether between). This parallel swinging of a whole face is an essential characteristic of all aether movements.

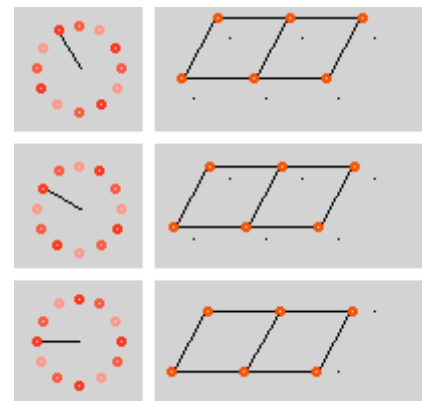

Cone, Crank, Double-Crank

The movements within the aether however are not limited to that pure similar behaviour of points. At picture 09.02.04 upside left at A are drawn three neighbouring points, which are connected by a black line. At such 'connecting-lines' numberless points are neighbouring, which are swinging analogue. As a simple track again a circle is marked. The circle left side shows a relative short radius, which is increasing towards right side. All point of the connecting-line keep constant distance between. However the right point is swinging at wider track as the points left. The whole connecting-line is moving in shape of a cone-mantle (marked light red).

This enlargement of swinging-radius is an essential characteristic of aether-movements. Also the Free Aether is moving at many circled tracks, however only at short round sections. Starting from that 'trembling' a radius of a circle-track can become longer (while the radius of other part-circles may become shorter), so the motion-pattern of these cones can come up.

If all aether would be completely resting, that mass would show infinite high inertia. However all aether is anywhere swinging, also the Free Aether. Its motion is a combination of many round track-sections, which finally are closed within each other. These motion-pattern are not completely rigid, but the axis of track-section may tilt and the radius may vary. The kinetic energy of Free Aether keeps constant as a whole, e.g. even when the tracks are stretched in shape of previous cone.

The track most wide finally must be reduced again to the narrow swinging of Free Aether. This cone at A thus must be complemented by a mirrored cone. This shape is called 'double-cone' or is also called a 'crank' (e.g. because the crank-shaft of one-cylinder-motor is an 'edged' variation of). At this picture upside right at B such a crank is sketched with a round connecting line. This line starts left from 'resting' Free Aether (blue point) and is ending right side again with a 'stationary' blue point. The neighbouring aetherpoints of the connecting-line are moving at enlarged radius, where the red point at the middle shows the swinging at most wide range (see arrow).

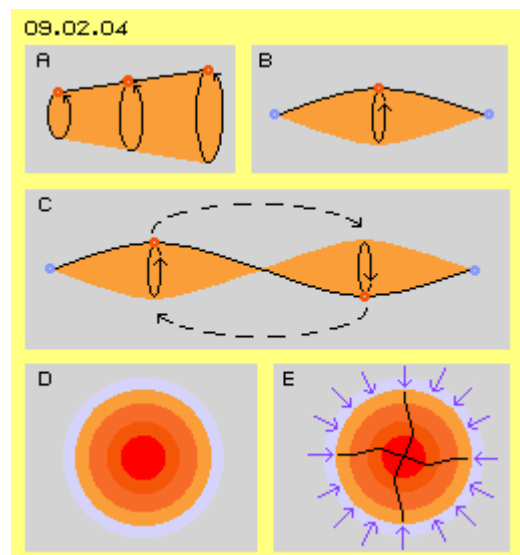

This simple crank is not already the optimum shape for a local limited swinging unit, because e.g. all aetherpoints upside must momentary also take a high position. A limitation for a local unit is achieved, if two such cranks are

combined to a 'double-crank' (by coarse comparison corresponding to the crank-shaft of a two-cylinder-motor). This point-symmetric arrangement is shown at this picture at the middle at C.

A spiral connecting line is drawn between the Free Aether, represented by both blue points left and right. The line shows the mantle of two 'spindles' (marked light red) during its swinging motion. The red aetherpoint left side did swing up, while same time the red aetherpoint right side momentary is positioned most down. So at the moment, upside-left exists 'too much' aether, upside-right however 'too less' volume exists. So the aether should 'slosh' from left to right side, like marked by dotted arrow. Below the situation is opposite and 'some aether' should swing from right to left side.

When the turning of the double-crank goes on, the balancing movements must work contrary. Finally results the motion pattern of a double-crank also at the vertical direction. This arrangement is a very important motion-pattern, because it allows compensation within a local area. For example this is the motion principle within an electron and a hydrogen-atom, thus the most appearances within universe (see next chapter).

Balancing-Areas, Aether-Pressure

So at the one hand exists the Free Aether with its 'nervous trembling' at narrow tracks. At the other hand exist local areas of Bound Aether, which show swinging movements better structured and at tracks longer stretched. The local units have no fix borders, but all around exists a transition-area, where the gradual stretching of tracks occurs by increasing radius of circled sections.

All local motion-units thus all times are embedded within a 'balancing-area', where movements of ambient aether are transformed into swinging-pattern of the inner space. At picture 09.02.04 below left at D that principle is drawn schematic. The Free Aether (light grey) can be called relative 'resting or stationary' (here represented by light-blue). The border-section with the transition of movement-pattern is marked light-red. From this balancing-area further inward comes up the ordered swinging at increasing longer radius (marked by different red).

This is the general difference between motions of 'material solid bodies' and the aether-internal swinging: a mechanic wheel rotates around its axis, where the angle-speed is constant, the absolute speed however is increasing from the centre to the rim. Opposite to that 'rigid vortex' the aether is moving all times in shape of 'potential vortices'. These vortices show increasing angle-speed and increasing absolute speed from outside inward (which is reduced only near the centre). Local movement-units thus in principle can only exist as 'potential-vortex-clouds'.

Starting from the border, the nervous motions of Free Aether rattle and pull at the ordered tracks of internal swinging. From outside exists a pressure, as the nervous rattling wants to enter that 'cloud'. The internal potential vortex can only resist, if its motion-pattern is well ordered and stabile within itself.

At this picture below right at E that radial pressure, affecting from the rim towards the centre, is marked by blue arrows. I call that appearance the 'universal aether-pressure' or 'general aether-pressure'. This general pressure of the ambient aether is rubbing off all motion pattern, if they are not stabile enough. Opposite, that all-around pressure keeps together and stabilizes the well ordered motion-units. At E the internal motion-pattern is marked by a vertical and a horizontal 'double-crank' (the extreme stabile motion-principle of the electron). Other internal motion-pattern result other physical appearances, e.g. the chemical elements. That general aether-pressure is also a decisive effect at motion-pattern representing electromagnetic appearances - as discussed in later chapters in extent.

Swinging with Stroke, Thrust-Effect

An other important characteristic of aether movements is schematic shown at picture 09.02.05. Upside was mentioned, all aether is swinging at sections or round tracks, also by multiple overlays. Simplistic one can imagine the motion at a circle track. At this picture left side e.g. a circling motion with radius R1 exists (marked by blue circled face).

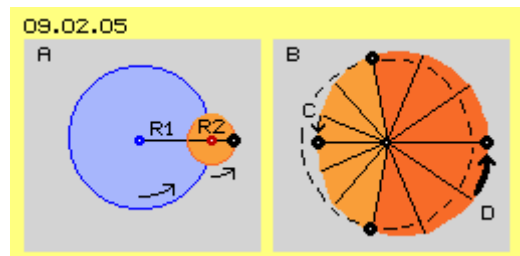

An overlay here is drawn, as around the end of that blue 'clock-hand' a second circling motion with radius R2 exists (marked by red circle face). At the outward end of the red 'clock-hand' the observed black aetherpoint is positioned. Depending on relation of radius-length and the turning-speed and turning-sense, most different tracks will result. Here simplistic is assumed, both circling motions are running by likely angle-speeds and likely turning sense (see arrows).

Right side at B the track of that overlay is shown, where the aetherpoint is drawn at four positions (which it takes during one turn). In comparison with the original (dotted) circle with radius R1, the track is enlarged at the one side (by length R2, here right side) respective some dented (here left). The aetherpoint is moving during one half

of time at a relative long way with increased speed (dark sector) and during the second half of time is moving at a shorter way and some slower (light sector).

This animation visualizes the motion process: right side the aetherpoint is moving much faster than at left side. There is a phase of acceleration and following phase of deceleration. A stroke-component comes up, which at previous picture is marked by thick arrow D at the right side. This fast stroke is compensated by the slower motion at the other side, like marked by small arrow C.

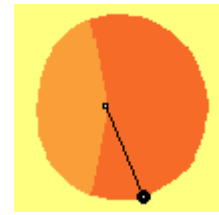

Here is sketched the most simple case, where the asymmetric motion results by overlay of only two circled movements. Within the aether can not exist pure linear movements (see upside at picture 09.02.02 at A), and also no swinging at exact circles can exist, just because many motion-components are overlaying within the aether all times. No matter which kind these overlays are, inevitably come up tracks with acceleration and deceleration. So within the aether nowhere exists a complete likely swinging, but in principle exist most variable motion processes.

If anywhere within the aether such a 'swinging-with-stroke' comes up, neighbouring aetherpoints must behave synchronous. The strokes can not run linear into only one direction (otherwise that stroke would run throughout the universe). That stroke-movement finally must run back, thus finally must be arranged 'all around the clock'. A face with such stroke-component for examples exists as a disk of about two million kilometer around the earth. Like at all potential-vortices, the stroke-component outside starts rather weak and increases inwards towards the centre.

These strokes are affecting a motoric force, e.g. by temporary deforming the local motion-pattern of atoms. Every stroke is affecting a minimum thrust onto material particles. Within that 'whirlpool' of the earth e.g. the moon is pushed around by about 1 km/s. Further inside the geostationary satellites are drifting around by about 3 km/s and thus in principle 'keep their position' above the equator. This motion-pattern however exists also in small and smallest dimensions. That motoric effect for example is also decisive factor at applications of electricity.

Possible and necessary

That first instinctive 'Impossible!' thus is only valid for solid bodies of our experienced material world. Within the part-less aether are no gaps, nevertheless most variable movements are possible. However the motion-possibilities are reduced respective just this results certain necessities of appearances. A motion can only take place, if an aetherpoint takes the place, which - same time - got 'empty' by a corresponding motion. Generally this is only possible, when all processes finally are running back to their starting points. As all movements in principle are running into all three directions same time, local motion-units can come up only in shape of spheres (e.g. like atoms) or disks (like e.g. galaxies) or flat faces (e.g. like charge on conductors).

These motion-units have no fix borders but must show a balancing area with smooth transition from trembling of Free Aether to the internal motion-structure. The surrounding aether affects a pressure at such spheres, disks or faces all times. Their swinging at longer radius and at tracks more stretched can only survive if the internal structure is sufficient stable, thus internal are running congruent motion-processes.

Something Moving

The appearances and processes of electric-technics are based on these properties of real existing aether. The most important characteristics are described upside. For background knowledge it would make sense to study the comprehensive considerations of my Aether-Physics (in 2003 and following years with parts 01 up to 04). Since 2009 with part 08. 'Something Moving' I was able to define the properties of the aether even more precise and to give plausible explanations for many 'phenomena' and diverse unsolved problems. At previous year I did show that 'Evert-Aether-Theorem' by a graph at the summary of that previous part.

At the following chapter at first are discussed some more relevant shapes of motion-units of Bound Aether. Afterwards these aspects can be transferred and applied to 'phenomena' of electric-technics - where possibly again could get 'something moving'.

Evert / 2011-07-15

09.03. Relevant Appearances

Perfect Swinging-Sphere

At previous chapter at picture 09.02.04 at C was shown a 'double-crank'. Its general motion-structure is sketched once more here at picture 09.03.01 upside left. The blue ring represents the ambient aether, which stabilizes that structure by the general aether-pressure. There is drawn a spiral connecting-line in horizontal plane and the area of that swinging double-crank is marked light-red. The aetherpoint A momentary is positioned below-left and the opposite point C upside-right. In order to keep distances between all aetherpoints constant, below an aetherpoint B momentary had to swing towards right side and opposite the upper point D must momentary be some left. These movements won't run linear up-down respective left-right, but all processes again are swinging at round tracks.

Upside right at this picture again a 'spiral-spindle' is drawn, now in vertical direction between 'north- and south-pole'. Its room for movements is marked light-green. Balancing movements here are demanded in vertical direction, like marked by dotted arrows E and F. This is practically identical to previous discussed horizontal double-crank at its equatorial plane. So both double-cranks are mutually conditional.

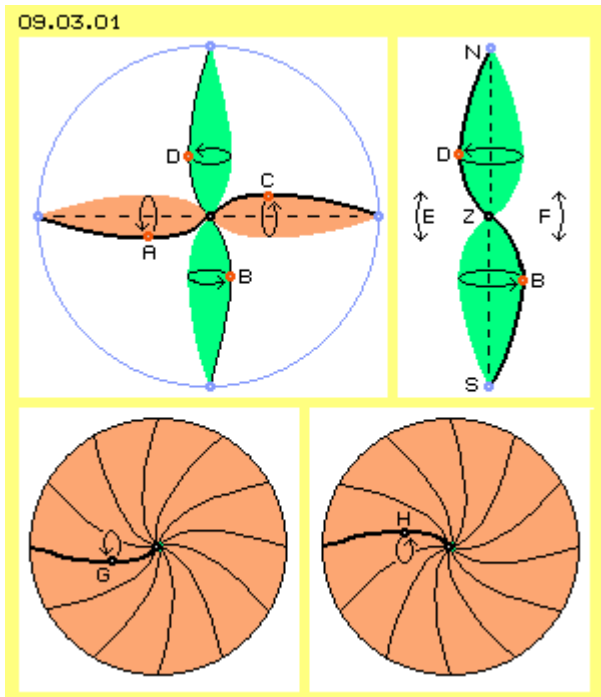

Below at this picture are drawn two cross-sectional views and each one connecting-line is drawn thick. At left side an aetherpoint G momentary is far down. Right side shows the situation one half phase later, where the same aetherpoint (now marked H) is positioned far upside. All around are drawn additional spiral connecting-lines, which all are swinging analogue. At this animation the motion process is visualized. All points at the connecting lines keep constant distances. At this cross-sectional view, all points are moving some clock-wise and afterward back again. Instead of the flat plane of this picture, in reality all movements naturally are swinging at round tracks.

Here are drawn only vertical and horizontal cross-sections, which in principle are identical. Each other cross-section results the same picture. The whole system is symmetric around the centre. The whole sphere is internal synchronous and uniform swinging. Starting from the ambient 'stationary' aether, the swinging movements are running on increasing radius. After a maximum the radius becomes shorter again, so this motion-pattern shows merely movements at the centre. This is the motion-principle of the electron, which is extreme stable-in-itself.

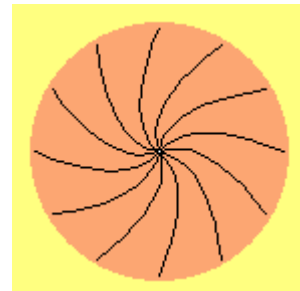

Clocks all around

At picture 09.03.03 upside both outside parts (light-red) of a horizontal double-crank are marked. The central part now however is drawn in shape of a ball (dark-green). At its left edge an aetherpoint A momentary is at its uppermost position and at right edge the aetherpoint B correspondingly is most down. All around the equator of that sphere, the aether shows analogue movements. Here these circling movements are marked by clocks and each end of a clock-hand represents an observed aetherpoint. Here the clock-hand left side shows upward and the clock-hand right side show down. The clocks between must be 'time-shifted' corresponding. The light-green band thus represents the area at equator, which is shown by total length at second row of the picture. At A the hand shows upward, at B the hand shows down.

Even all clocks are turning by likely speed, different distances come up between the ends of the hands. When two hands are positioned horizontal and show into opposite direction, long distance C is given. When two hands show towards each other, a short distance D is given. At the row below, all hands are connected by a curved line. Within one half of time, the connecting-line is long stretched (E, black), at the second half of time (F, blue) it's shorter. So the distances between aetherpoints would no longer keep constant - what is not admitted within gapless aether.

Distances of different lengths did also come up at previous discussed 'swinging-with-stroke', which also here could bridge the divergences. At the other hand, all movements occur into all three dimensions of space at same time. These 'clocks' must not be arranged exactly right-angle to the equatorial plane. If the clock-hands would be inclined some inward at the long distances E, the ways become shorter. If opposite at the short distances F the clock-hands would be directed some outside, the ways become longer. During the swinging all around the

equator, thus constant distances between all aetherpoints are well possible (however the equator would appear little bit pulsating).

At the row below a simplistic solution for that problem is drawn. Within gapless aether all movements must occur conform. Here the principle is a likely swinging of all aether around the equator. These clocks can not show same 'time' everywhere, otherwise all aether would swap upside (and pile up at one pole and flatten the other pole) and at the following all aether would flow down. In order to balance these movements, the clocks must turn 'time-shifted'. So the aether can swap some up-and-down all around. It is not necessary to arrange the clocks symmetric (as assumed upside). The clocks well can be positioned near together (like at G) or some far off each other (like at H). Then the aetherpoints of the black connecting line are constant. They keep constant while the swinging, when the fulcrums are not totally stationary. At the other hand this problem is not grave, because these twelve clocks must not be time-shifted exactly one hour.

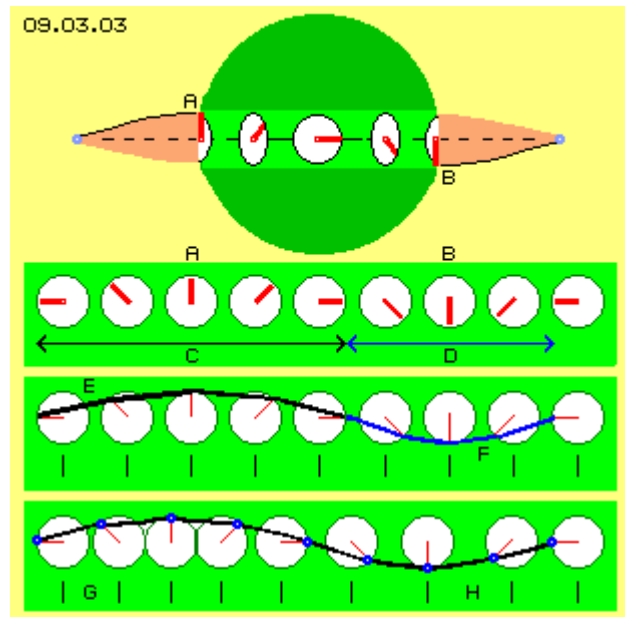

Unequal

When searching for the 'perfect' motion-pattern, one 'naturally' assumes circle-round processes and 'naturally' should result a geometric exact sphere. At the nature however do not exist exact straight lines, circles and spheres. And also the previous fulcrums must not necessary be symmetric arranged. The processes are strictly dictated by the properties of the aether and as it's gap-less, constant distances between the aetherpoints are demanded. Thus unequal movements must result and sphere-shaped motion-units thus 'naturally' must show dents and hills.

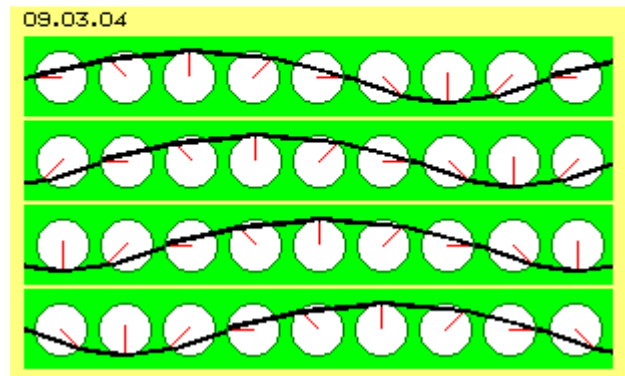

An electron is a very small motion-unit, a photon is even much smaller, so the dimensions of these swinging movements must be smaller again. Previous 'clocks' are overdrawn at least be thousands. Also strong overdrawn are the curves of these connecting lines. If the radius of that motion-unit would be one meter, the line could differ from a straight line by only one millimeter (as I suggest). So previous 'problems' are most oversized. In addition the balancing movements within that sphere occur into all three dimensions all times. Within that unit do not swing these few lines and not only in pure shape of that double-crank. Realiter exist numberless swinging motions at spiral winded curves within that tiny electron - permanent moving, however never totally equal.

Waves

In this connection an other appearance must be mentioned, which is shown at picture 09.03.04. There are drawn nine 'time-shifted' clocks of previous picture. The ends of clock-hands represent the observed aetherpoints. These are connected by a curved black line. At the first row, the curve builds a hill at left side and a depression at right side.

At the second row, all hands did turn by 45 degree counter-clockwise and again at the following rows. All aetherpoints thus describe a half circle (and will come back to their starting points after following four time-sections). That's the real movement of the aether at relative narrow space. Besides this however an additional seeming motion of the curve appears: the wave-hill wanders from left to right and also the wave-valley.



At this animation one can observe the turning of each clock. The tips of all hands are moving on a circled track. In addition comes up the impression, the wave as a whole would be steady shifted towards right side. This is an other example how real motions at the background are resulting additional appearances. Like at Platon's cave one could register and believe the wave being reality, even it's only the secondary result of the real process. We will meet that wave-pattern some later as an essential appearance of electricity.

Swinging-Variations

At previous clocks, the swinging was assumed at simple circled tracks. As motions within the aether are overlaying all times, pure circles practically can not exist. Upside already was discussed, how motions with stroke-component come up by overlays. This motion-process is drawn once more at picture 09.03.06 left side at A and B. Resulting is a deceleration left side at G and an acceleration right side at H. Here is drawn only one black aetherpoint and its track. Within the aether all neighbouring points must move (nearby) analogue. So whole areas of likely swinging will exist. A 'field' of that asymmetric motion-structure affects a pulsating thrust onto local motion-units. That's why e.g. the planets are pushed around within the sun-whirlpool. This thrust-component also is affecting at electric-technics as 'motoric force', as discussed at later chapters.

This picture at C shows, both radius R1 and R2 can have different length. Above this, the turning-speeds can vary and also the turning-sense can be likely or contrary. Depending on constellation, an observed aetherpoint will move at most different tracks. At D for example is sketched a frequent appearance in shape of two loops. The aetherpoint is moving at an outward bound spiral track and afterwards comes back at a narrow spiral track. This motion equals loops of varying size, where again there are phases of acceleration and deceleration.

The resulting tracks can take most different shapes, e.g. ovals or 8-shaped, stretched or compressed, forward- or backward-turning. The tracks can also build loops or 'garlands'. Above this, the radius of circles must not keep constant length or constant relation of lengths. This allows smooth transition within motion-pattern respective the shape of motions can steady vary. If local motion-units (e.g. of atoms) collide, they mutually become deformed little bit and the internal swinging functions like springs. Here these processes are drawn only two-dimensional. Realiter these motion-components occur in three dimension. Thus many possibilities exist for balancing 'tensions', e.g. to guarantee constant distances between neighbouring aetherpoints all times.

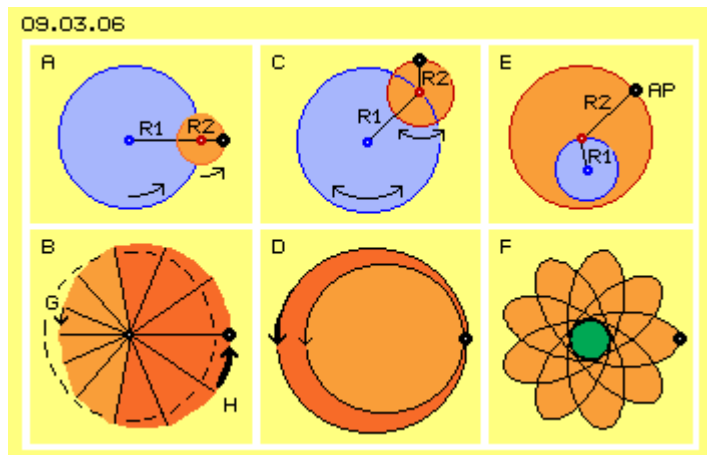

An important variation is sketched at this picture at E. There is a relative wide swinging with radius R2 (face marked red). The fulcrum is not stationary, but wanders around at relative short radius R1 (marked blue) around the centre. Resulting is a 'rosette-pattern', like shown at F. Depending on ratio of length, turning-speed and turning-sense, the observed aetherpoint moves at long and sharp or broad and flat loops, more or less far and fast around the centre, by loops wandering forward or retrograde. So infinite possibilities exist for motions into all directions. There is only one limitation: neighbours must behave adequate. However this does not demand everywhere only pure identical movements within the gapless aether. Smooth transitions are possible all times, e.g. simply by varying length of radius.

Indeed, the rough wallpaper-design of previous 'clock-pattern' at picture 09.03.03 can not be decorated all around a ball. Finally with the complex motion-pattern of picture 09.03.06 such spheres are possible. Just the variations and smooth transitions allow the complete balancing within a motion-unit. The sphere is the most perfect body. All circles automatic are closed within themselves. Thus also local changes in principle and necessarily will finally be balanced.

Internally the movements are limited by the 'pliability' of the aether-substance. The 'bend-ratio' probably is less than 1:1000, i.e. the aether also within a local unit is nearby stationary with only minimal motions. Towards outside must exist gradual adaptation to ambient Free Aether. However there are no fix borders and the 'surface' of such motion-spheres is permanent 'vibrating'. The stability of such motion-units comes up only by the general external aether-pressure. Finally that's why motion-units appear 'hard' or even to be 'particles' which can interact with 'materia or physical fields'.

Electric Balls

I know it's hard for many readers to visualize such complex processes within space. Probably one never will know exactly the motions within an electron, just because they are too small and invisible. At the other hand there are examples in huge size, in shape of 'ball-lightning'. Diverse reports of these appearances exist from earlier days. Preferably



these lightning balls came down the open fireplace, rolled around and disappeared also through closed windows. So for some moments these thunderstorm-born units were stable until they dispersed (see old picture 09.03.07 upside).

Today merely exist fireplaces with an open sooty chimney. So these appearances are rather seldom and even more rarely photos were made (e.g. at an underground car park, see picture below). At special labs occasionally such 'energy-bundles' are generated. Also there one could not detect the internal structures exactly. At any case these must be electric fields, closed inside themselves. The air-particles inside are ionized or transferred into a plasma-state. The material particles however are shining only as a secondary effect. The huge energies by themselves can only exist as fields, fields can finally exist only in shape of movements, which can not exist within nothing. Thus also these ball-lightning must exist by the aether, which is swinging most intensive within that local unit.

A Face and a Pipe

Nevertheless some critics negate spontaneous and categorical, motion within gapless medium could be possible at all. I would like to try once more to make that possibility plausible. At picture 09.03.08 left upside at A is drawn a section with diverse layers. The blue layers upside and below represent Free Aether (here called stationary, even their aetherpoints are 'trembling' on narrow spaces). The dark-red layer represents aether, which is swinging at wide tracks. All aetherpoints of that layer are swinging parallel to each other. Here that swinging simplistic is sketched by circled tracks, however also could be a swinging-with-stroke or by varying loops or at rosette-tracks of previous picture. Only important is, all aetherpoints are moving parallel to each other.

Towards upside and below these motions must be reduced to the narrow nervous trembling of the resting Free Aether. That's why balancing-areas are demanded, here marked as light-red layers. The reduction of motion-intensity is done in shape of double-cone (resp. simple-crank) and representative for all aetherpoints here only three double-cones are marked light-green at the faces. Within these balancing layers again all neighbours aside are swinging completely synchronous, so also here all distances between aetherpoints keep constant.

Thus between resting aether-layers well can exist faces of aether with wide swinging movements. One could rebuild that motion-model just pure mechanical. Between two surfaces (blue) many parallel rods are installed, which all are bended likely. At the middle (dark-red layer) they could be connected for keeping constant distances (and also at horizontal layers of balancing areas as you like it). At the ends the rods are beard turnable. If the rods are little bit elastic, they also could be fix installed within the stationary layers. At any case now the middle layer can do swinging movements (at round tracks as you like it). The rods represent the function of connecting-lines - and corresponding to that mechanical model, also within gapless aether can exist internal movement - within the frame of its possible curvature (which here is extremely overdrawn).

No matter how large these planes are, they allow parallel swinging between planes defined stationary. At this simple motion-model some problems come up only at the borders. At the planet Jupiter these problems e.g. result most violent moving surface with storms and turbulences (especially because Jupiter shows also retrograde swinging layers, see chapter 08.20 'Aether-Vortices of Gas-Planets'). Here for example this problem will come up again by conception of sheet-capacitors.

At this picture right side at B, now that flat motion-pattern is rolled up in shape of a pipe. All around a central stationary core (light blue) exists a balancing area (light red) with the increasing swinging movement up to a round layer of maximum motion-intensity (dark red). By an external balancing ring (light red) the movements again are reduced to size of ambient Free Aether (light blue). The double-cones of connecting lines thus here are arranged in radial direction (not drawn here). Again the swinging can run at simple circled tracks, can show a stroke-component or build loops or rosettes etc. The motion-pattern all around is closed within itself (only at the ends of the pipe previous 'border-problems' still exist). Such pipes with huge volumes of moving aether e.g. build 'canals for flash-lightning' (see chapter 08.20. 'Normal and Paranormal Appearances'). Analogue processes are discussed at the following concerning current at round conductors.

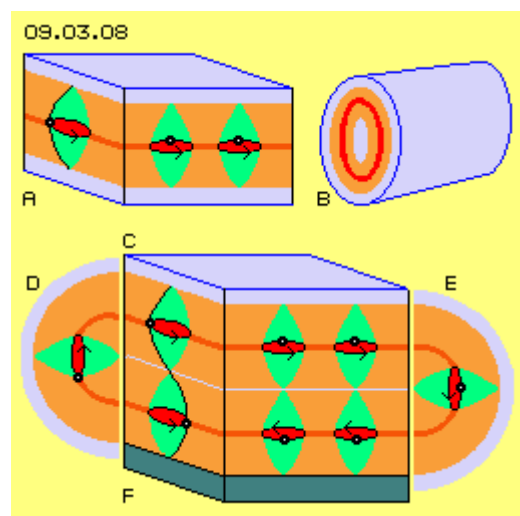

Two swinging Layers

At this picture below at the middle at C, once more a section through diverse layers is sketched. The layer of Free Aether again is marked light-blue. The layers of balancing movements again are marked light-red. Now two layers of intensive swinging are marked dark-red. Now three double-crank are marked light-green. Some Aetherpoints are marked black, the circled arrows show direction of swinging movements. A spiral black connecting line

represents the shifted swinging of both layers: if an aetherpoint on one layer momentary is positioned in the background, the corresponding aetherpoint of the other layer is positioned in the foreground. So both layers of intensive movements are swinging phase-shifted.

This offers a solution for previous 'border-problem'. During the contrary swinging of both layers, momentary e.g. a face reaches 'over the border' while same time the other layer is ending some back. So at the borders must occur an exchange in vertical direction. This will not occur linear but by tracks of round bows. Left and right side at D and E, such bows schematic are sketched - and each corresponds to one half of previous pipe. So one can easy imagine as limitation for the swinging faces, all around the borders exists a 'half-pipe' (previous pipe divided in longitudinal direction).

Opposite one can imagine, the pipe at B is cut in halves and between both round halves that block C is inserted with its plane layers. Like all swinging is closed in itself within the pipe, all motions within the flat motion-pattern inclusive rounded borders will run endless without problems (again also at simple circled tracks or by swinging-with-stroke or at loops or rosette-pattern etc.).

At this block below, the layer F is marked dark-grey. That 'stationary' face could exist e.g. by copper and thus would build an electric conductor. The swinging of aether-layers upside of that solid layer one well can call 'electric charge'. This motion-pattern is pressed against the surface of the conductor by the general aether-pressure. The narrow and nervous trembling of the Free Aether wants to enter that ordered motion-structure. If however that pattern internal is well ordered, it resists the pressure respective opposite, the charge is conserved at that surface by the ambient Free Aether. The charge layer is pushed everywhere to likely height at the conductor.

Electron blast-off

So one easy can imagine, all around the swinging block D 'half-round edges' exist, corresponding to previous pipe longwise cut in two parts. At the corner of that block, both 'half-pipes' meet, naturally not straight but again rounded. That rounded corner practically builds one quarter of a sphere.

Through these charge-layers can run disturbances or vibrations, which naturally produce increased movements especially at such corners. Thus that 'quarter-sphere' could get blast-off the edge. As all aether is forced to move synchronous at its best, neighbouring aether is forced to accomplish that part to a complete sphere. If this is not achieved, that motion-fragment is 'shreddered' by the Free Aether. If the supplementation occurs sufficient - a new free electron is born. Thus electric charge and electron will really show similar motion-pattern, the charge by a flat ordered swinging, the electron by sphere-shaped structure. An electron thus indeed is a 'drop of electric charge'.

Aether-Model of Atoms

An electric conductor exists by atoms. The structure of atoms was explained by Bohr in comparison with the planet-systems. Many scientists however assume, an atom is not build by elementary-particles, no protons and no neutrons exist at all and no electrons are running around the nucleus at diverse tracks. The quantum-theories believe, elementary-particles are build by quarks. Up to now about thousand different 'particles' are known. Strange enough they permanently change the shape and some exist only for minimum time. Everybody may believe it or not.

By my view of the aether, the atoms are compounds of diverse vortex-spindles, arranged radial to the centre and building a sphere-shaped motion-unit. At 09.03.09 upside left at A for example is sketched a cross-sectional view, showing eight spindles

(respective double-cones respective simple cranks). The best arrangement is achieved by pairs, because they can build double-cranks at a diameter of the sphere. At one side the swinging appears left-turning, like marked by arrow L. By view from outside at the opposite side, that swinging appears right-turning, like marked by arrow R.

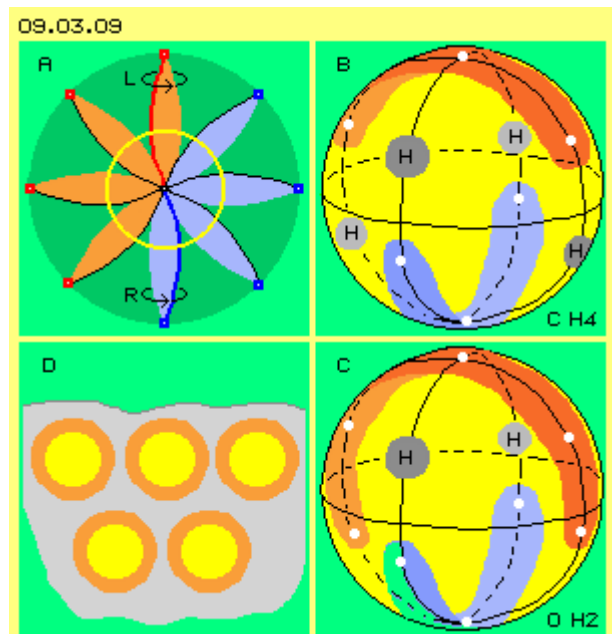

In order to differ the real electrons from these vortex-spindles, I call them 'eyes'. An atom has as much eyes as commonly electrons are assumed. At this picture upside left, the sphere-shell of most intensive swinging motion is marked by a yellow ring. Upside right at B this area schematic is sketched as yellow surface of a hollow-sphere. When the eyes are spread equal at the surface, at least two 'islands' come up, one with left- and one with right-turning vortices. The example shows the six-valency carbon-atom with each three left-turning red and three right-

turning blue eyes. There come up two horseshoe-shaped 'ridges', each with likely sense of swinging. Between these hills are areas of balancing and thus less motions. Into such 'sunks' for example four grey hydrogen-atoms can 'nest', thus building molecule CH₄ as a whole.

At this picture below right side at C, an eight-valency oxygen-atom is sketched, however in shape of an isotope with five left- and three right-turning eyes. The sunks between the hills build docking-stations e.g. for two grey hydrogen-atoms, resulting the molecule H₂O. As mentioned, that's just my answer for the insufficient explanations of common theories. I explained these consideration comprehensive at chapter 08.13. 'Aether-Model of Atoms'. With concern to electric-technics only the surrounding shell of the atoms is important.

Membranes

At this picture below left at D schematic are sketched some atoms. Around the yellow 'core' of the atom a balancing area is marked light-red. Depending on suitable shape, atoms can build a stabile molecule or a compound more or less solid. The balancing areas are merging and thus a common 'aura' encloses the whole structure. As the aether inside and around the atoms allow common swinging, also the surrounding Free Aether is moving in similar shape.

If such motion-complexes as a whole are well structured, also the environment will get into ordered swinging. If the atoms are arranged in regular grids, also the Free Aether between is moving accordingly (areas marked light-grey) and at the outside face a joint shell comes up. In optimum case the surface of that 'aether-membrane' (dark grey) is so even, flat charge can stick on especially good respective 'current' can flow along such conductors (like shown in details at later chapter).

Elasticity

At picture 09.03.10 upside left at A two atoms schematic are sketched. The areas of intensive motions are marked yellow and the balancing areas are marked light-red. The 'aura' is much wider than commonly assumed, like here sketched by additional light-red rings. Already from a distance, such units 'feel' the presence of the other one. If the movements fit well, the atoms can 'lean' against each other, e.g. also building H₂- or O₂-molecules. Often however the motions are contrary, at least temporary, so the atoms keep 'proper' distance.

At B two atoms are moving towards each other, like e.g. by steady collisions between gas-particles. The vortex-spindles (of previous picture at A) become compressed into longitudinal direction like 'springs' and accordingly must extend aside. The increased tension affects stronger mutual pressure, so the atoms fly off again.

At C both atoms did crash so hard, their contours became deformed. Where the atoms meet, comes up a broad bulge, which here e.g. is marked by 'pear-shape'. The sphere-shape is optimum because certain volume is enclosed by most small surface. The 'movement-volume' now at the bulges has enlarged surfaces, so the general aether-pressure will affect stronger (see blue arrows). Both atoms thus are pressed back into their original sphere-shape - and same time the atoms mutually are pushed off and finally flying off.

That process occurs inevitably only within a gapless medium. Only here each impulse is completely returned. Only by that background fact, e.g. a gas keeps constant temperature, in spite of numberless collisions between the huge number of particles. If the atoms would swim within 'Nothing', strong collisions would result similar deformations. However a part of the deformation-impulse inevitably would run off into the surrounding nothing, thus would get lost without any effect. As the universe up to now does not show energy-loss, the aether inevitably must be gapless and can not exist by particles. Only based on this aether-property, elastic pushes can occur without losses.

Stressed Aether

At this picture right upside at D now a situation is shown, where both atoms did crash very fast. In addition the vortices at the meeting-point momentary are swinging contrary sense, like marked by both curved arrows. Upside as an example, the connecting-lines were compared with elastic rods or finally with steel-springs. At both cases, the pliability is limited, just like within the aether. That hard collision and compression of the contrary vortices result 'stress' within the aether. The most strong winded connecting-line forces all neighbours to analogue motions and that demands enlarged balancing areas, far beyond the original sphere-shape of the atoms. At this picture this is marked by an extreme light-red extension towards right side.

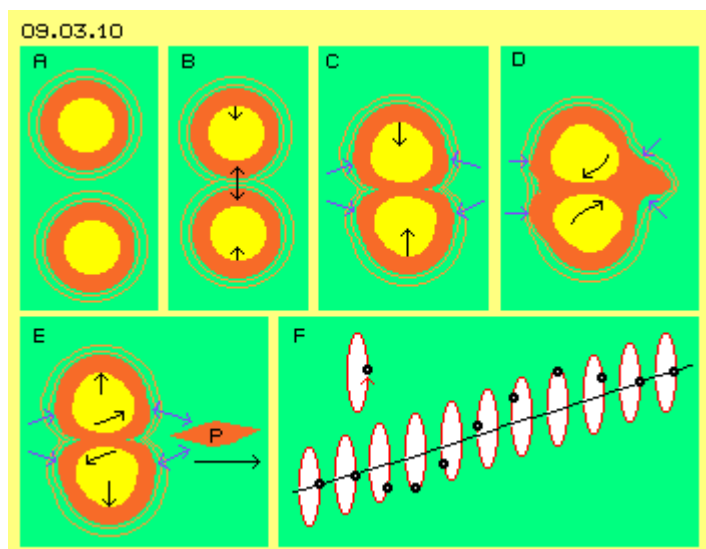

Naturally the general aether-pressure works against this extension. If however the aether between the atoms is tensioned up to the limit of its curvature-possibilities, the necessity of diversion is much stronger than the normal swinging of Free Aether. Nevertheless, the general aether-pressure will strongly affect onto the side-flanks with their wide surfaces (see blue arrows right side). A part of the bulge can be cut-off and thus a part of the stress-causing winding is redirected towards outside. If e.g. a tungsten-wire is heated strongly, its atoms are trembling extreme fast within their grid - and push off such photons.

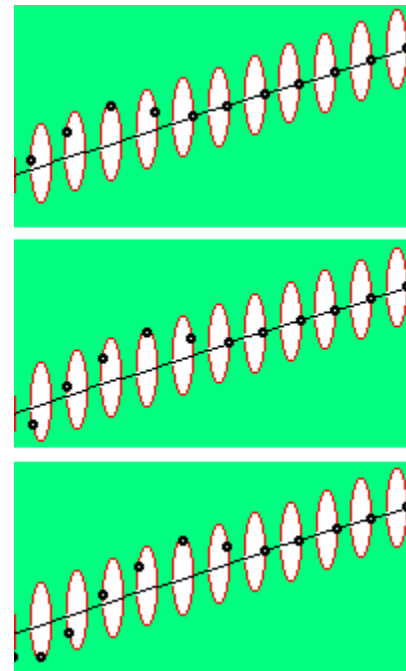

Photon

At this picture below left at E, the dark-red vortex-complex of photon P already got some off towards right side. It is further pushed off by the general aether-pressure and at the other hand, the bulges of both atoms are pressed back (see blue arrows). As the photon flies off by light-speed, the internal motions of atoms must run at least as fast. That 'liberation-stroke' thus occurs extreme fast. Same time, the vortex-spindles of both atoms are already swinging back (see black curved arrows, each now showing into contrary directions). This swinging-back reduced previous tension. That's why the elimination of the stress-situation demands only one turn for creating the photon. The deformation of both atoms now is reduced to 'normal' degree (like e.g. sketched at C), so they can fly off according to normal collisions.

At previous picture below right side at F, the motion-pattern of a photon is shown and visualized by the animation. All neighbouring aetherpoints (in the direction of the flight) are swinging only once around at circled track, however each some time-shifted. The frontside aetherpoint is just starting the movement, the aetherpoint some behind did move already some longer way at its track, the aetherpoint most back did return already to its original position and keeps resting there.

So when a photon is running forward, no particle is racing through the space. All aether in general keeps stationary. Only the motion-pattern is forwarded through the aether. That pattern is most simplistic: swinging only one turn around, at the frontside the circling starts, increases to the middle, afterward reduces back to 'standstill', finally at rear end of the pattern.

Thin flat Disc

At picture 09.03.12 once more the source and cause of the motion-structure of the photon is shown. At A the starting situation is sketched. In principle the aether between the crashing atoms must 'escape' and that deviation-movement B is running at the frontside of the photon on and on. In principle this must be compensated by a return-movement C of the aetherpoints to their original locations. This does not occur at two-dimensional plane, but that red 'hill' is twisted, so the connecting-line is represented by a spiral wended curve.

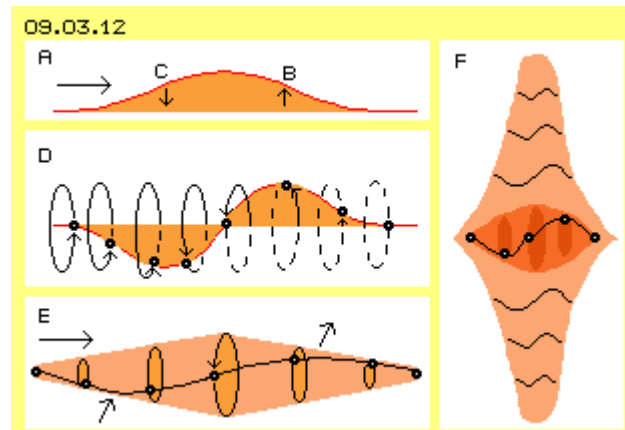

At D once more is sketched, no aether and no 'photon-particle' is running through the space. Instead of, all neighbouring aetherpoints start swinging off their place at a round track and come back again to their old spot. The impression of a 'wave' running forward comes up only by the fact, the circling movements of involved aetherpoints occurs time-shifted.

The motion-pattern thus again is a double-cone respective a simple crank. Their space of movement is marked light-red at E. At every moment the connecting-line of neighbouring aetherpoints builds a spiral curve. That motion is started by 'hard collision' of atoms. The gapless aether allows the progression of the impulse without loss, quite real (like otherwise only assumed pure fictive by theoretic model of 'ideal gas'). The permanent 'thrust' comes up by general aether-pressure, which at second half of time pushes each aetherpoint back to its original place (see arrow left side). This push is moving aetherpoints inside of that motion-unit spiral-diagonal towards frontside and outward. So by likely force aetherpoints at the frontside of the photon are pressed off their original location (see arrow right side).

This increasing and reducing of motion-radius, in principle is identical to cranks and double-cranks of motions inside of electrons and atoms. New is only the fact, that structure same time is wandering forward within the aether. Into longitudinal axis the radius can temporary get longer and shorter again at that 'cone-mantle' without

problems. The photon thus can show relative short 'wave-length'. However, the width of a photon commonly is far beyond common assumptions. The 'amplitude' of suggested 'wave' is much wider than expected.

At this picture right side at F, a black spiral connecting-line is drawn and the area of its swinging is marked dark-red. The sideward-movements force all neighbouring aetherpoints to analogue swinging and all distances between must keep constant all times. Such simple-cranks have only one swinging plane and theoretic they are reaching infinite wide (see previous 'border-problem' at picture 09.03.08 at A). The situation is only moderated because the simple-crank is winded and thus shows some balancing effect within itself. Here that gradual reduction is marked by smaller spiral curves upside and below the core-area. However I suggest, a photon will be hundred to thousand times wider than long (as usual, these drawings can not be true to scale, otherwise the principle would not be visible. Realiter the light-red area should be drawn much wider).

By view of that aether, thus the 'electromagnetic waves of visible spectrum of frequencies' appear other kind: as a concrete motion-pattern in shape of a spiral winded swinging disc, which is relative thin however extreme broad, and only the structure of the movements is forwarded through the aether, which in principle keeps stationary all times. Naturally this understanding has far-reaching consequences, e.g. for simple explanation of refraction of light. The results of unfortunate 'double-slot-experiments' are easy to explain and one could leave the ill-fated idea, that innocent swinging-bundle would finally decide its behaviour by observing the observer - and insane conclusions of that kind.

Motion-Structures

Within the scope of the Aether-Electric-Technics it's not necessary to believe in these ideas about atoms, electrons and photons in all details. However it's important to understand the progression of motion-units through the aether: only the structure of movements is forwarded, nothing else. The photon is just a one-turn-swing of aetherpoints, frontside first. Somehow more complex is the shape of an electron, in principle however it's again an assembly of such vortex-spindles. When an electron wanders through the space, again only that pattern is transported forward. Atoms are even more complicated accumulations of vortices, however also the atoms go ahead within space not as 'material particles' but only the complex motion-pattern change locations within the aether. It might be startling for some reader to be only a complex vortex-compound, existing not steady by certain basic material, but being an only transient pattern of motions, which flits across the universe-wide aether - however inclusive 'far-reaching spirit-vortices plus indestructible soul-pattern'.

No, these strange ideas are not prerequisite for understanding the new Aether-Electric-Technics. However, here is the declared aim to replace the common abstract terms of charge, current, fields, repulsion / attraction etc. by totally real motion pattern of aether within the aether. The partly strange effects (e.g. left-hand-rule) are 'nature-laws' - and their inevitable results are only to explain by a gapless aether with its inevitable inner compulsion and restrictions. So the reader at least should accept the decisive properties of that aether as an realistic alternative to common doctrines (with their obvious phenomena and unsolved problems). Only by that understanding of the real existence of that aether, the following discussions might result advanced knowledge (otherwise the reader should stop reading here).

Evert / 2011-07-31

09.04. Charge

Source of Charge

At previous chapter are discussed two appearances of electricity: at the one hand the electron as a sphere-shaped motion-unit swinging within itself, at the other hand the electric charge as a flat motion-pattern. Now here the question is, what's the source of the electricity. A simple answer would be: the sun - because all energies available at earth finally are delivered by the sun. Indeed, the sun sends an endless stream of charged particles, which e.g. build 'electric clouds and flows' at the ionosphere. However, for direct access by common electric technologies these energies are much too far.

At earlier chapter 08.17. 'Aether-Vortex of the Earth' (at picture 08.17.22) was shown, why the whole earth-surface is covered by an electric charge. The axis of the earth is some inclined to the plane of its aether-whirlpool. The equator is moving faster within space than the pole-regions. At the night-side the vortex-systems of sun and earth are turning into likely direction, at the day-side they are turning contrary sense. So all around the earth are demanded balancing movements within the aether. They build long-stretched vortex-strings, resulting the 'field-lines' or earthly magnetfield. At the other hand these aether-'curls' can result round motion-units. These electrons stick at 'material particles' or are drifting free within the atmosphere. Towards the earth they appear denser. They sink further down and finally build a closed charge-layer at the earth-surface.

Charged, negative or positive

Electric charge is easy to produce and to prove, like shown at picture 09.04.01. If one rubs e.g. a PVC-ruler (A, grey) with a wool-fabric, at the surface comes up negative charge (dark-red, marked at the edges). If now one keeps that ruler near to an electrometer, it shows the existence of charge. Obviously the charge reaches to both tin-foils (B, grey) via the distance C through the air (and also through a 'vacuum'). As both foils are charged likely, they mutually repulse each other.

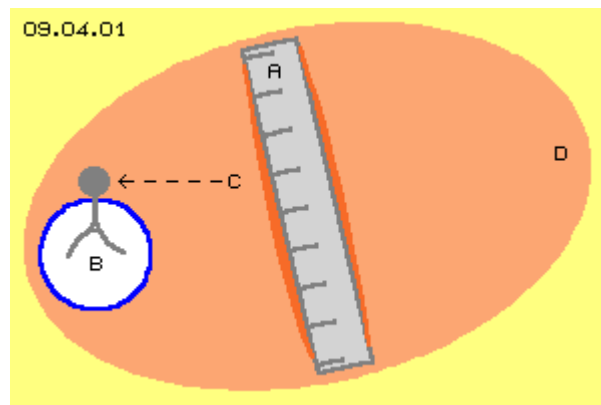

That process is totally other kind than mechanic effects between solid bodies or the behaviour of gases and liquids (even also these appearances finally are based on aether-movements). Here however a real effect is achieved which directly and exclusively is done by invisible aether (if no longer one sticks to the fiction, real effects could be possible through the 'nothing'). Upside was already mentioned, all accumulations of atoms are embedded within a commonly swinging layer of aether. In addition to that 'aura' now an electric charge is all around the surface (and easy can slide along conductors). The 'aether-shell' of the charge obviously reaches far out. The involved aether-volume (D, light-red) of that charge thus is multiple wider than the ruler.

Also if one strokes a cat-skin, charge is generated. However here the electrons are removed from the hair-tips and transferred to the hand: the cat now is charged 'positive' and the person is charged 'negative'. Walking on a valvet-pile carpet shows an analogue result. By each step the threads are bend-over and are mutually rubbing. The involved aetherpoints can not shift alongside each other. There must come up balancing movements, by parts resulting these sphere-shaped motion-pattern of electrons. These are removed from the tips of the threads and pushed all up along the whole body. Probably the involved aether around that person will reach out by ruler-length all around. This is not visible normally, however clearly to feel short time before touching the door-handle. The valvet-pile carpet now is not 'charged positive', its structure only allows generating electrons. That person indeed carries more negative charge. The door-handle won't be charged positive. When ever it carries less charge than the person, charges become equalized by the flying spark.

Lightning

Electric charge is generated at thunderstorms by huge extend. Hundreds of lightnings struck at the ground every second. These energies exceed human demand by far. Unfortunately that's not usable by common electric technics. At previous part 08. 'Something Moving' (and book with that title) are described the thunderstorm-processes at chapter 08.15. 'Normal and Paranormal Appearances' in details. So here only some relevant aspects are repeated by view of the aether.

Within storm-clouds in general, air- and water-masses are pushed up and are falling down like a paternoster-lift, by speeds up to 150 km/h. Huge accumulations of free electrons finally come up at below edge of storm-clouds, as a result of 'friction-electricity'. At mechanic processes comes up 'friction-heat' which is simple to explain: energy is demanded to overcome friction between solid bodies and thus the molecular motion of particles is accelerated corresponding, thus generating 'heat'. The generation of electricity by friction however is only to explain by the behaviour of a real aether.

Decisive are the 'nearby-collisions' between the particles at storm-clouds. When these vortex-complexes 'scratch' aside each other, they show contrary movements at least by parts and temporary. The aether between these particles is 'stressed' and the situation is only released by additional balancing vortices. These motion-shreds are dissolved by Free Aether some later - or some of are pressed into a stabile sphere-shaped motion-pattern by the general aether-pressure. These electrons can stick at 'material particles' and thus building ions. When ice-particles are colliding or melting, the electrons are pushed off again. Finally a huge amount of free electrons are drifting within space - and do not know where to go. They were neither attracted by the ground nor by upside clouds which are assumed to be 'positive'. As pictures 09.04.02 show, a lightning can 'wander around' far distances before they find that one kilometer down to the ground.



Traces

An electron is much smaller than an atom, nevertheless it demands a volume of space inclusive its aura. Like particles of a gas, the free electrons are flying from one collision to the next. The less the way is hindered by other vortex-complexes, the longer distances they can move straight forward. Other electrons can follow the 'empty' track, until all electrons are dammed up by next barrier. The electrons of a lightning thus come straight forward only by centimeters. That 'traffic jam' finally will break up into direction of weakest resistance.

At picture 09.04.03 upside left at A, an electron (red) is sketched, resting within Free Aether (blue). The electron at B is moving down. So an additional movement exists within the aether, demanding correspondingly wider space for balancing movements. Only the extreme simple vortex-pattern of the photon (only one turn) can 'screw-ahead' within the aether by light-speed. All vortex-systems more complex however demand wider aether-volumes for additional forward-motion. This is marked by the light-red face, however strong overdrawn. When 'material particles' are moving, this effect results the increased kinetic energy respective inertia respective the 'mass' increased infinitive when moving by light-speed.

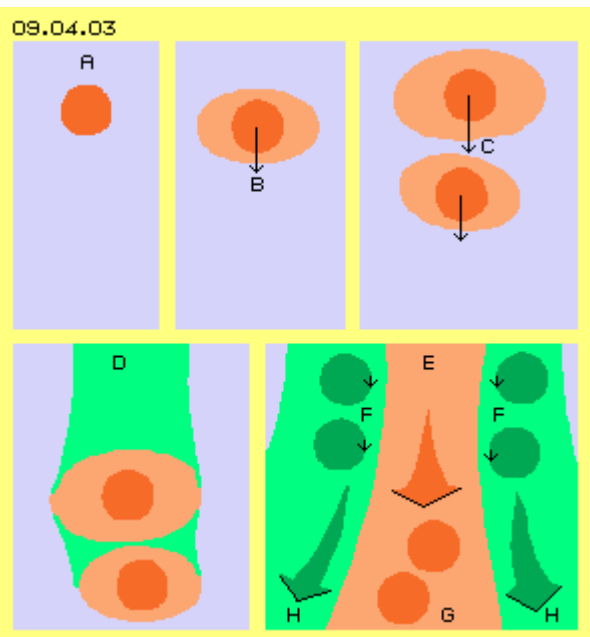

At C this electron has move further down and a second electron can follow, even by higher speed. At D both electrons did go on flying down. However no 'particles' are falling down. The aether is 'stationary and resting' all times. The aether at the track of an electron takes only the motion-structure of the electron for a short moment. If this vortex-complex did pass-by, this area will take its previous or original motion of Free Aether. If now however the same or similar motion-structures did pass an area repeatedly, that aether does not come back completely to the status of Free Aether. The fast follow of electrons practically leave a trace, which is marked light-green at D.

Lightning-Canal

That trace shows rests of motion-pattern of the electrons respective is similar to their aura. The 'rosette-pattern' (of picture 09.03.06 at F) might fit best to these movements. However the loops won't be completely symmetric, because e.g. the general forward-motion has a 'stroke-component' all times. At this picture 09.04.03 below right side, that trace E is marked light-red, because it corresponds with the passing electrons to a great extent. The red arrow marks the general direction of the strokes. The 'motion-core' G of electrons can race through that trace without resistance.

So many similar movements occur within that canal in rapid succession. The increased motion-intensity demands new balancing-motions. These additional involved aether-volumes are marked by light-green areas aside. Again they must show analogue vortex-structures. Opposite, now the electrons can flow through the canal like 'at ball-bearing' (at F, dark-green, marked schematic). One knows well, the lightnings do not only exist by electrons and

not only by charges bound to 'materia' (as usual). That appearance is called 'charged space' (even no explanation is known up to now). The real motion-structures of that real aether within these areas are the vortex-complexes presented here.

The stroke-component naturally must exist also within these pipe-shaped lightning-canal, like schematic marked by arrows H. The motion at centre and also at areas all around force the aether at the end of canals to analogue swinging motions. That tube is searching the way of minimum resistance like a trunk. Finally when a branch (more or less by chance) did reach the ground, whole 'charge' can ease up at wide face. Finally now the canal extends enormously and gigantic 'electric energies' flow to the ground and spread at the environment.

Knee-deep

So by common understanding, the earth in total is charged. Most part of charges is spread at the earth-surface. Also the atmosphere is charged, however decreasing at the height. The average strength of electric field near the ground is about 100 V/m between surface and atmosphere. As that little bit rubbing at previous ruler resulted an 'aura' of 30 cm, probably we stick within a strong electric field, at least knee-deep and at all times. So we need only to 'pick up' that everywhere existing energy - even it's not just a simple job.

The electrons of previous velvet-pile carpet lifted up to the fingers without problems. Just likely, that 'earth-charge' wanders up the whole body, also up to the roofs and up to the mountains. All materia at earth surface is embedded within that 'natural electric charge'. That's why no potential differences come up and we don't feel anything about that general existing electricity. However this means also, at the environment is nothing without charge.

Only negative Charge, only more or less

Already at school we learned, there are positive and there are negative charges. The electrons 'naturally' are charged negative - however the examples for positive charges are scarce: a positron should build the counter-part of an electron and when meeting, they mutually destroy each other. At times of big-bang, 'by chance' came up more electrons, so only the rest of these negative charge-carriers finally remained. We also had to learn, all protons of the atomic core are charged positive. We also had to learn, likely charges are repulsing mutually. Strange enough that's not valid for protons, because hindered by an imaginary 'strong nuclear power'. Why and how this could function at all, still is a secret - like usual at Platon's cave.

Naturally one can calculate with positive and negative numbers. Numbers are an expression for quantities - however nobody did ever see a negative quantity of real stuff. Opposite, here can not really exist positive charges - no matter how often it's drummed into everybody's head. At picture 09.04.04 is sketched the school-example of 'influence, charge-constant and charge-separation', which easy proves the previous claim.

There is a metal sphere A which is not charged and a metal sphere B with negative charge. If both are moved near to each other, the previous 'neutral' sphere gets a positive charge C (why and where from it ever might come). Based on theoretic necessary charge-constant, a corresponding negative charge D comes up at the opposite side (where from it ever might come). Now the sphere could be separated into two half-spheres (at the middle, see dotted line). Now one half-sphere shows positive charge and the other shows negative charge. All this happens according to known physical rules. However it's absolutely uncertain whether the basic idea of the supposed model is according to the reality.

Based on upside considerations, any materia is surrounded by (negative) charge. So also the 'neutral' sphere E is embedded within an aether-layer of charge (dark-red), inclusive an aura of balancing swinging motions (light-red). The sphere F bears not only few negative 'elementary-charges' but a relative thick layer of charge (dark-red) and naturally shows an 'electric field' (light-red). That swinging motion reaches far out into the neighbouring space. If now both spheres come near to each other, contrary aether-movements are meeting. The stronger 'field' compresses the weaker field and pushed that motion-layer along the sphere-surface to the other side. The unchanged 'mass of charge' now is spread unequal at the sphere-surface: at G by a thicker and at H by a thinner layer of charge.

All charges however are of same kind and keep likely character. All charges all times are negative. Thinking by polarity antagonism allows simplistic 'laws', which however might lead to misconceptions. In reality exist no diametrically opposed items, but only more-or-less - and every student can easy understand. Instead of 'positive / negative' thus here terms are used like 'high charge' (HC), 'normal respective average charge' (NC) and 'low charge' (LC). This describes how 'mighty' a charge-layer is respective what's commonly might be called 'charge-density'.

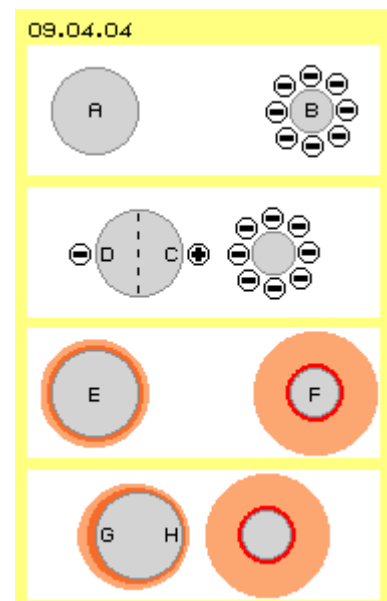

Crucial Experience

When starting a car, at first one must turn on the key. Sometime I had a 'key-event' which is sketched schematic at picture 09.04.05 upside. By common understanding, the electrons are carrier of the electric current. These are 'pressed' into the storage battery (B, grey, respective accumulator) of cars by the dynamo. From that current-source the consumers (V, blue) are fed and the electrons wander back to the battery. The conventional direction of current is declared as a flow from plus- to minus-pole. The real flow-direction is contrary. Here all times the real direction of current is used, so flowing from minus to plus (see arrows). Correct however is only a flow from high to normal or to low charge (see below).

So by common understanding the production of a 'surplus' of electrons is valuable. At a short-circuit these electrons immediately flow off via earth-wire into the ground, until the fuse blows off. At a car-battery, the electrons come out from the minus-pole - and that pole is short-circuit with the motor-block respective the car-body, so indirect also with the earth E. Obviously exists an abundance of electrons and thus they are not 'valuable' at all. The car-key (red, within yellow box) does not protect the minus-pole but the plus-pole. That's rather strange, because a water-tap or a gas-tap naturally is installed before the consumer. Here however is allowed / hindered not the outlet but the inlet of the electric source.

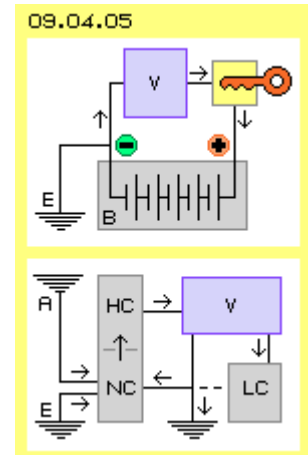

The valuable element within that circuit thus is not the minus-pole as source of the current, but the plus-pole as the sink of the current. However the electrons available all around are not usable by that conception. Chemical processes are running within batteries and the minus-pole delivers just as much electrons as the plus-pole can take. The free available huge 'sea of electrons' thus could be used only by processes which occur independent from chemical reactions.

Source and Sink

The general principle for usage of general given charge and thus the usage of 'Free Energy' schematic is sketched below at this picture. Normal charge (NC) could be gathered via antenna A from the atmosphere, e.g. like Tesla did catch his 'radiations' or ions respective free electrons. At the other hand, the normal charge of earth E could be used as a source. Many devices are 'grounded' and one must be aware, that's not the wire towards 'zero-charge'. This is a matter of fact - however many devices of Free Energy probably won't function or are only fairly working, because that fact is not consciously used.

A new kind of 'transformer' (grey) is demanded for conversion of the normal charge (NC) into high charge-layers (HC) respective high charge-density. Resulting is a voltage-gradient and that potential-difference between HC and NC could be used by consumers (V, blue). Afterward the charge can flow back into the NC-HC-transformer or flow off to the ground (see arrows). This function already is done by any transformer or generator - however at first the current must be produced by motoric drive. Here naturally the aim is an autonomous production of high charge - and some known constructional elements do that job nearby (as discussed some later).

An even higher potential-difference would exist with a constructional element, which can produce low charge (LC, grey). It's probably hard to achieve a charge-level below the average level of the environment. If that would be possible, temporary the flow could fill that sink up to normal state and the normal charge could serve as input for previous transformer (see dotted line). Naturally it would be the optimum, if a 'never-filled-up' sink could be build. Then a permanent potential-difference between high charge HC and low charge LC would be available. Probably already the potential between normal charge NC and a real zero-charge would be usable.

This might sound crazy and incredible. However some known constructional elements already do that job somehow. Tesla reported several times about an 'ultimate sink'. However he was not allowed to speak quite frankly but only by 'allegorical examples'. It's objective of this Aether-Electro-Technics to discuss such constructional elements - at right time. Beforehand a remark: in 2005 I published a chapter 'Aether-Energy-Generator' at my website, where e.g. also the usage of given radiations was mentioned. Some of these considerations and constructions are not good, some are really good. In the meantime I got additional knowledge. Suitable elements of that chapter thus here will be included in improved shape.

Multi-layered

Before making conceptions for new constructional elements, at first some basics must be discussed, e.g. concerning diverse aether-layers. Starting point of the aether-physics is the fact, only one real substance exists within whole universe. All other appearances are only movements of aether within the aether. The atoms of 'normal materia' are complex motion-pattern in sphere-shaped local units. Inside of exists ordered swinging at relative wide tracks. As a transition to the relative chaotic 'trembling' at narrow tracks of the Free Aether, each atom needs an area of balancing movements all around.

Also around the molecules exists a common layer of analogue swinging aether, so e.g. H₂O is embedded within a common 'aura'. Also accumulations of particles again are embedded within a common aether-layer, which e.g.

keeps together a water-drop. Also accumulations of atoms of solid bodies build a common surface. The swinging of aether around a conductor one could imagine e.g. like a crop-field at hilly landscape is swinging with the wind (by rather coarse comparison). It's well known, all living beings show an 'aura', e.g. like Kirlian-photos demonstrate. Finally for everybody a 'sound' aura is vital.

With these considerations about aether-electro-technics, around all these bodies an additional layer of swinging aether comes up, known as 'electric fields'. However these fields up to now were handled only as fictive models and not as a real mechanic movement of a real aether (opposite, one is proud these effects 'need no substantial medium'). Here however the motion-pattern of electric / magnetic fields will be described as precise as possible. So the appearances of electricity should be clearly differed to previous mentioned manifold swinging layers of the aether. That's the aim of following chapters.

Evert / 2011-08-15

09.05. Current

Emergence of Lightning

A huge stream of energy flows to the ground when lightning strikes towards the earth. At picture 09.05.01 once more the main characteristics of that occurrence are sketched schematically. The causing process are the 'nearby-collisions' of air- and water-particles (A, grey) within the storm-clouds. Sometimes some balancing aether-movements are necessary between these vortex-complexes, which sometimes result in the sphere-shaped motion-unit of an electron (B, red). The electrons temporarily can dock at material particles, finally however many free electrons whirl through the aether, especially at the lower part of storm-clouds.

An analogue to gas-particles, the electrons collide and fly chaotic into all directions. They can fly long distances, if few obstacles in shape of other aether-vortices exist. Into that direction of few resistance one electron can follow the other. The aether by itself is stationary and takes only temporarily the motion-pattern of the electron passing by. Immediately behind that vortex-complex the aether comes back to its previous motion-shape, as a rule the 'trembling' of Free Aether. If however many electrons are racing as a fast follow through the same track, the aether of that area will not come back to its original motion-shape in total. The electrons leave behind a 'trace', which is marked light-green at C.

The internal pattern and the movements between the electrons mutually adjust. Within that 'formation' comes up an area of relative uniform and intensive swinging (marked light-red at D). The environment therefore is forced to increased balancing movements (marked light-green at D). Resulting are areas with the typical motion-pattern of moving electrons, thus prevailing a rosette-pattern with steady variations into all three directions of space.

These motion-units are not stable all times. Many branches of lightning are racing from one cloud to the next and disappear again (like sketched at F). The Free Aether forces all motions into its 'nervous swinging at narrow room'. Only if the vortex-systems show a stable motion-structure, they can resist the pressure of Free Aether. At the other hand, diverse branches of lightning can merge and force the ambient aether into their motion-pattern.

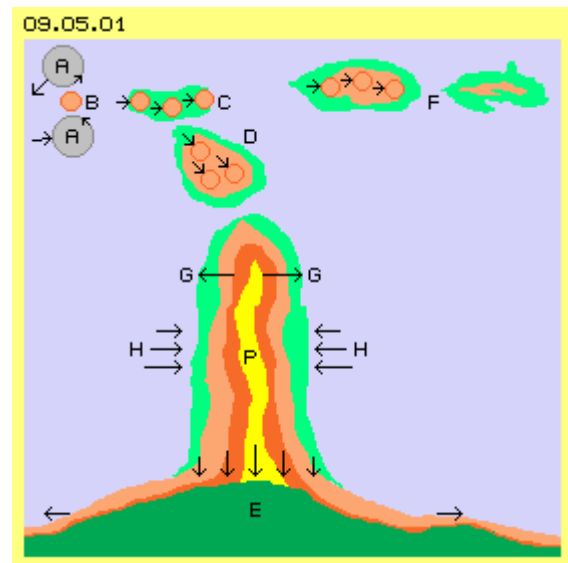

Normally the lightning comes forward only by short steps. At each step a forward-directed motion-component comes up, building a 'slipway' at the borders. That slide path will be tube-shaped because there the motions can run all around and thus in endless loops. Like mentioned upside at picture 09.03.08 however the 'border-problem' remains, here at the front-end of that pipe. These turbulences hinder the progression of that branch again and again.

Striking of Lightning

This situation changes abruptly when a lightning-canal (by occasion) arrives at the earth (E, green). Then the swinging and striking movements suddenly can spread at a wide surface. Now all tensions by dammed-up motion-components are released. Within whole canal an equal 'flowing' comes up and these intensive motions demand additional balancing areas. Resulting is a 'pressure' onto the ambient aether (see arrows G). Even the air-particles are pushed aside (and their following 'implosion' produces the sound of thunder).

Quite analogue is the process within the aether: the strong extension of the lightning-canal builds a much wider surface, so some later the general aether-pressure compresses that 'motion-tube' (see arrows H). At this phase no longer exist separated electrons. By many steps (marked by different colors) that canal increased by additional layers of balancing motions, thus by shells of analogue motion-pattern. At the other hand, a contrary pressure comes up each time. Upside at these unstable motion-rests F resulted the dispersion of that structure. Here however the motions are enclosed in this canal, so all aether within is forced to according swinging motions. At the centre of the canal often comes up a synchronous swinging at wide tracks, which mostly is called a 'plasma' (P, yellow). So a plasma is not the 'fourth physical state of materia' but an especially intensive swinging motion at relative wide tracks, which are closed in loops - however existing by nothing else than quite normal aether.

At the location of lightning-strike temporary exists extreme high charge. This does not exist by separated sphere-shaped electrons, but by intensive swinging aether at flat layers. The 'electric current' again is produced by the general aether-pressure, which flattens that 'motion-hill'. When all processes calmed down, the earth-surface shows the normal charge level - which still does not exist by electrons, but is a synchronous swinging layer of aether.

Swinging-Pattern of Charge

A swinging-pattern of charge was already shown at an earlier chapter at picture 09.03.08. A part of this picture here is shown once more at picture 09.05.02 upside left at A. In principle, that swinging motion is running in shape of a double-crank, because that pattern allows balancing of aether movements at narrow space. If a part of that swinging is pushed off the edge, that motion-pattern can be accomplished to a sphere-shaped unit. Thus the stable structure of an electron might result. Indeed, at sharp edges of conductors (and also of non-conductors) electrons are emitted. So an electron practically is a 'drop of charge' with likely motion-pattern. The electron is swinging motion in shape of a sphere, while charge is represented by a flat swinging movement.

The static charging of a ruler was discussed at previous chapter at picture 09.04.01, which once more is drawn here at this picture upside right at B. Most remarkable is the electric field (light-red) obviously reaching far out into the space. The height of the charge (dark-red) at the surface of the ruler obviously can not be only one electron (as assumed at A). The swinging must occur in many levels, thus in shape of many double-cranks. Here are drawn some black connecting-lines, multiple spiral twisted. The electric field is produced by the motions of many 'spindles' of that kind. All spindles are moving parallel to each other, however must not behave totally synchronous. The radius of all motions will steady vary in vertical and in horizontal directions.

At this picture below left at C, the green face represents a horizontal plane within an electric field. Here again are drawn clocks to visualize the movements of observed aether-points (each at the end of clock-hands). In principle, all clocks could turn likely and all hands could shown into likely direction. Then the whole face is swinging totally synchronous, however the aether would 'spill over the border' all around. This problem is reduced when the clocks are time-shifted, e.g. like here sketched from left to right and also top down. The black connecting-lines of observed aether-points build waves, here into both directions.

At an earlier chapter at picture 09.03.04 was shown, how the 'hills and dales' of waves wander through the aether. The connecting-lines represent neighbouring aether-points, which in principle keep their location. Nevertheless the wave-movements can affect thrust onto other vortex-complexes. If that swinging does not occur only at simple circle-tracks, automatic and inevitably come up movements-with-stroke (see earlier picture 09.02.05). This asymmetry is balanced by the contrary movements at both levels of double-cranks. In addition upside was stated, these 'clocks' must not be arranged totally parallel to the plane, it must not exist likely distances between, they must not turn totally likely and likely fast. Like upside mentioned as a rough comparison, one can imagine the charge like swaying crop-fields.

Here at this picture, the direction of movement of wave-pattern is marked by arrows E and F. At D is shown, how that flat pattern (red) is rolled around a conductor (grey). Instead of previous green plane, now the swinging-level represents the green ring at that cross-sectional view through the conductor. Again are drawn previous both directions E and F, which inescapably come up at each difference to an exactly conform circled swinging motion.

Drive-Direction - Left-Turning

For a change, here a quote of text-books: "When an electric current I flows, a magnetic field H comes up within the vacuum. Within the air one observes the magnetic induction B all around I . B and H are connected via $B = \mu H$ with μ = permeability. The direction of H is determined by right-screw-rule: if the electric current shows into direction of screw-feed, H shows into turning sense of the screw" (by conventional definition of current-direction).

I do not like such abstract statements, because the essential facts are explained better by simple sketches, e.g. like at picture 09.05.03 upside. Here however the current all times is looked at by its real direction, thus flowing from minus to plus respective all times from high charge HC to normal charge-density NC (or even to low charge LC). The current thus flows along the grey conductor from left to right, like marked by the blue arrow. As

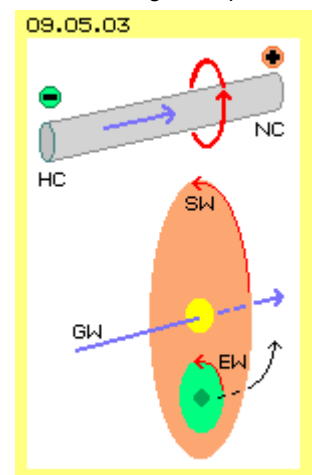
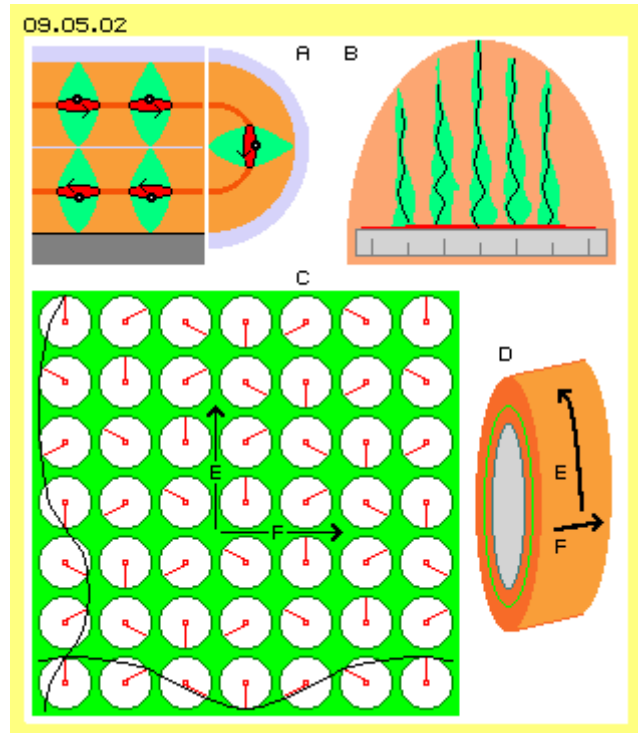

mentioned upside at the clock-example, this motion is coupled with a second movement. This is running at right-angles to the first, thus around the conductor-wire, like marked by the red arrow. The rule for both motion-components realiter is: by view in direction of real electric current, the according magnetic flow is left-turning.

Galactic Law

This is a 'nature-law', which one has to obey, even no obvious founding exists. Only one fact might be quite sure: the electric like the magnetic fields demand a real medium, because they have real effects on 'real materia'. Possibly the reason for that left-turn-rule might be shown at this picture below: the sun is moving within the galactic whirlpool GW, here into the direction of the blue arrow. Around the sun (light-yellow) everything is left-turning within the solar whirlpool (SW, light-red). Embedded is the whirlpool of the earth (EW, light-green), which is also left-turning. So the earth (dark-green) is moving within galactic space spiral-forward left-turning. Above this, the earth by itself is left-turning around its axis. Above this, all turning-axis are mutually inclined. All these motions are based on motion-pattern of the aether. So probably the aether at earth-surface in general is impressed by that 'in driving-direction left-turning'.

For explanation of movements within the aether, as starting point was used a clear circular motion. Each overlaying movement results asymmetric processes, e.g. also inevitably a pushing strike-component. All aether, at least within our galaxy, however is not 'neutral'. It shows already motion-components, which make the sun and planets drift within space. So also the Free Aether at the earth is not really 'stationary-resting'. Thus pure circle-movements can not serve as a basis. All additional movements are already overlaying these multiple left-twisted spiral-movements. So e.g. also the motion-structures of an atom are based on that galactic-solar-earthly motion-cocktail.

Atoms and solid bodies as compounds of vortex-complexes react as a whole at changes of direction and speed, according to mechanical laws, finally and all times in shape of their inertia. The electric and magnetic fields (mainly) exist outside of these materia-units. So electromagnetism occurs direct within the aether. These fields are motion-pattern which are directly 'stamped' on the 'Free Aether of galactic characteristic'. When these 'open' structures are locally moving (e.g. electric current is running along a conductor), obviously they must obey the usual way: never straight forward but all times screwing forward like left-threads.

Wave-Hills of Direct-Current

At the following the characteristics of DC are discussed. At picture 09.05.04 upside at A the general principle is sketched. A generator (G, red) takes charge from the earth (E) and accelerates it, so electric flow is generated. This current flows all times only into one direction (see arrows) along a conductor, thus in shape of DC. A consumer (V, blue) uses the 'energy of that flow'. The remaining charge flows back to the earth. At first is assumed, the generator does the job of acceleration by separated pushes.

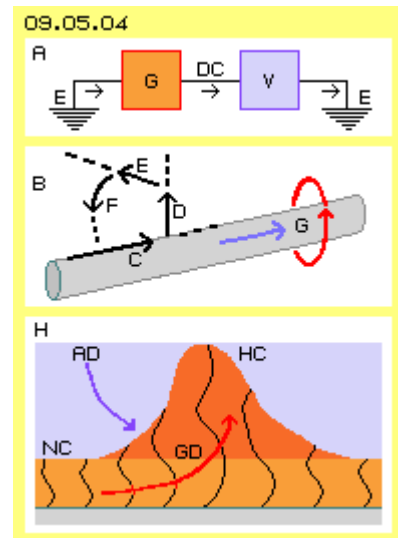

At B the process of acceleration is sketched and (simplistic) one could compare the aether with a fluid. Along the round conductor (grey) the aether is pushed forward, like marked by black arrow C. This linear thrust is hindered by resistance, because at the frontside already exists aether-volume. So that motion must swerve aside like marked by arrow D. However also there exists resistance demanding a second redirection, by right-angles as marked by arrow E. All linear motion along the conductor is affected by likely resistance and all around the forward-movement is redirected. All arrows E are showing around the conductor, as marked by arrow F. Now this movement is without resistance, because involved aether-volumes mutually escape at this circle. So a pushing acceleration into longitudinal direction of the conductor inevitably demands a circling movement around the conductor (like marked by blue and red arrows at G). Theoretically these diversions could also turn right - within a neutral environment. Obviously however the left-turn is embossed at the aether of our galaxy so strong, every additional movement of electromagnetic fields must behave accordingly.

At this picture below at H a grey conductor is drawn at the bottom. Above its surface is marked the layer of normal charge (NC, light-red), which is present all times. The acceleration-pressure of the generator (see red curved arrow GD) piles it up to high charge (HC, dark-red). The swinging of normal charge (NC) is marked by small double-cranks. With that pile-up of charge these spiral-twisted connecting-lines now are reaching far out into ambient space. The swinging occurs at longer radius, so outside additional aether must take balancing movements. The connecting-lines become multiple twisted, e.g. like at the environment of previous ruler. So that thrust-impulse of the generator produces intensive motions along and around the conductor, thus is working against the 'resting' Free Aether.

As soon as that impulse becomes weaker, the Free Aether can work against this 'disturbance'. The general aether-pressure reduces the swinging movements to their normal (average) size. This process occurs at the backside of the 'charge-hill'. So the general aether-pressure (AD, blue curved arrow) pushes that 'flow-wave' forward along the conductor. At the front, the 'motoric impulse' of the generator is still running forward, at the rear the Free Aether in addition is pushing forward that piled-up charge.

Longitudinal Spindles

Previous considerations once more pointed out, linear movements are problematic while turning movements are easy running within the aether. At picture 09.05.05 upside left at A this 'DC-wave' is sketched by longitudinal cross-sectional view once more. The current is moving from left to right. Around the conductor (grey) the swinging increases, achieves a maximum size and decreases to the end. This is practically a double-cone, like shown several times at previous chapters. The photon is the most simple pattern of that kind, which same time is running by maximum forward-speed. There a single-crank does only one turn which is 'screwing' forward through the aether.

The conductor inclusive this DC-wave are much thicker, e.g. with diameters of some millimeter. No aether is ever turning around such a wide radius. At this picture upside right at B the conductor (grey) is drawn by cross-sectional view and the wave (light-red) around it. The seeming wide-range motion around the conductor realiter is the result of many small vortices (green circle-faces). Every aetherpoint is moving only within a narrow area and all neighbours are swinging parallel and likely sense (see arrows). A motion turning around the conductor finally comes up by an asymmetric swinging: every aetherpoint is moving at a 'track-with-stroke', where the fast track-section shows into tangential directions. Analogue to the potential-vortices, the stroke-component becomes stronger towards inside. This corresponds to the motion-pattern of an 'aether-whirlpool'.

At this picture below right at C the proportions correspond some better to reality, however they are not really true to scale. The conductor has a radius much wider, the electric current is running within a relative thin layer. As charge and also the current stick at the surface, the conductor inside can be hollow or can exist by non-conductive light material. Here the centre is drawn light-grey and the hollow-conductor is marked dark-grey. Around the surface of the conductor exists a layer (light-red) of swinging aether. This is a compound of many synchronous turning tiny small vortices (some of are marked as green circle-faces with arrows). Normally the conductor is enclosed by an isolating coating, which here is drawn light-grey with black border. Below left at D is drawn a corresponding longitudinal cross-sectional view.

Instead of that wide-range turning around the conductor (like drawn upside at A), the 'flowing of current' occurs only within a narrow area between the surface of the conductor and the inner side of the isolator. All small vortices are very thin however long-stretched spindles (light-green). At the tips thus the aether-movements must be extended only at a relative small radius. Like a photon these sharp spindles are 'screwing' forward within the aether. However this is only possible along a conductor, because only these materials show an according 'aura' at the surface. At the other hand, the materials of isolators impede this process. The available ring-shaped face thus might be 'only some atom-diameter' thick.

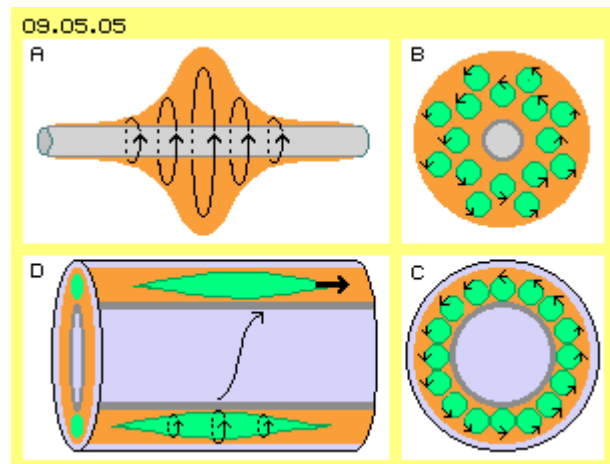

At 'static' charge e.g. of previous ruler, the spiral-twisted connecting-lines respective the aether-vortices 'stand upright' at the surface. This is also true for resting charge at a conductor. As soon however a forward-impulse comes up, the vortices 'tilt' into longitudinal direction - and analogue to photons the motion-pattern of these spindles can move nearby with light-speed along the conductor-surface - even or just because all aether is swinging only at most narrow tracks.

Energy is Movement - of Motion-Pattern

Photons are smaller than electrons by hundred times and thus only few aether is involved. Even photons are racing by light-speed, they show few kinetic energy. If previous thin spindles have a diameter e.g. like electrons, thousands can swing parallel within that small ring and numberless around the conductor aside each other. If that motion-volume is moving by light-speed, that 'flow' has considerable kinetic energy - even no particles nor aether is racing forward.

However the conditions should fit to the motion-necessities of the aether at its best. When using flex-wires - naturally left-twisted - the aether can move along screw-shaped faces. Instead of round flex-wires also flat and spiral-twisted copper-tapes could be used. The isolation between the tapes could reach further out, so wider cross-sectional face is available for the current. As all movements are running synchronous, the outside isolation-

cover won't hinder the flow, but protects it from occasional disturbances of ambient aether. The motion-pattern of the current penetrates also the aura and outer area of the conductor. If its particles can not swing resonant, the forward motion of the current is hindered.

Also small aether-vortices between the atoms are shifted some forward: the free electrons within the conductor are 'crawling' forward up to one millimeter per second. These electrons thus can never be the 'carrier of electric current'. Also the model of a magnetic and an electric 'field' does not match the reality. Electric (direct-) current is the result of many very small and very thin 'vortex-spindles', which are swinging synchronous around the surface of a conductor, where that motion-pattern is 'screwing' forward within the aether nearby with light-speed.

Pulsating or steady Flow

At picture 09.05.06 upside at A, a generator pressed a light-red 'wave-hill' at the conductor and some later a second, marked dark-red. These forward-impulses are transferred into thin spindles, which are racing along the conductor-surface. As shown upside by example of the lightning, the aether does not come back to its original shape of Free Aether after a fast follow of similar movements. This happens especially within that 'protected' area between the conductor and the isolation-coat. At this fast follow of pulsating DC the spindles become long-stretched and finally build an 'endless rope' of uniform movement.

At second row of this picture at B are drawn two generator-impulses, which send direct-current 'phase-shifted' into the line. The 'voltage' keeps nearby constant respective the steady high charge here is marked by the dotted line. The whole space available around the conductor thus comes into a constant uniform swinging movement and that synchronous long-stretched motion-pattern is running forward without resistance. There are no more disturbing motion elements. Just opposite: these movements represent kinetic energy - which can never get lost within the gapless aether. Here that motion-shape is protected against outside disturbances from the beginning to the end of the wire - thus the steady DC can do nothing else but flowing forward on and on.

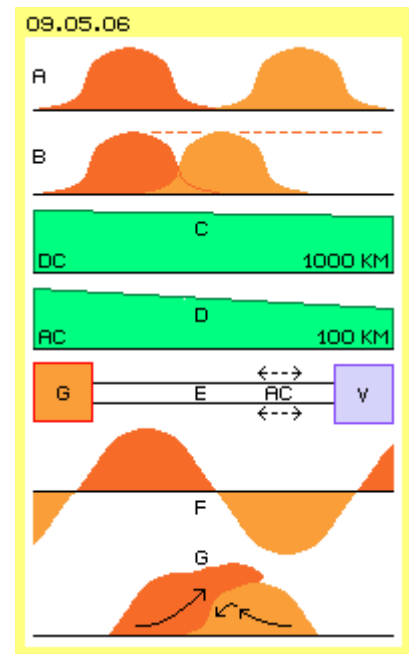

At next row C a graph is drawn, showing a drop of five percent: that's the decreasing-rate of energy by the transport of DC - at a distance of 1000 km. Just these days a tv-message reported a success-story for ABB in Mannheim: electric energy of wind-parks at the North-Sea is transported to South-Germany via special procedure in shape of DC - with nearby no losses.

Alternating Current

Next row D of this picture shows a corresponding graph with a line decreasing by 30 percent: this is the loss-rate of the transport of alternating current AC - at a distance of only 100 km. The general principle of AC-technology is schematic sketched at row E. Between the generator (G, red) and the consumer (V, blue) must exist two wires at any case. At both conductors AC is flowing, alternating to-and-fro (see arrows). At three-phase-current (discussed later) in principle are demanded three times two wires. A 'star-circuit' demands only four or at special cases only three wires.

The alternating current has some essential advantages (also discussed some later). The changing voltage builds nice (sinus-) curves at the oscillator, e.g. like schematic drawn at row F. The generator practically is a 'vibrator' as it presses hundred 'charge-hills' onto the circuit each second, fifty times into the one direction and fifty times into the opposite direction (in USA even with 60 Hz). The real processes within the aether however are 'disastrous', like sketched at below row G of this picture.

Loss, Chaos, Adversity, Unhealthy

A light-red wave-hill comes back from the consumer, here from right to left side. It is some reduced in comparison with the dark-red wave-hill, which some later is pressed onto the wires, in contrary direction, thus here from left to right. Both hills meet and the new high wave-hill practically spills over the old and weaker hill (see arrows). All around the conductor all vortex-spindles hit frontal. The new spindles are stronger and finally overcome the old spindles. At this crash exist controversial movements, demanding corresponding wider areas of balancing movements. Afterward, the Free Aether crushes down that 'motion-bump'. However a part of the motion-shred is rubbed off and radiated into the environment. One can feel this physically below high-voltage power-lines, at distance of many meters.

Finally after some delay, the synchronous swinging of all vortex-spindles is regenerated. Their stoke-component into left-turning sense, commonly is called an 'induced magnetic field'. It's not astonish, it comes up some later, phase-shifted to the 'electric field'. Both fields are suggested to build right-angles (analogue to the arrows C and E at previous picture 09.05.04). In reality, both are only two components of one motion-pattern moving spiral-

forward within space - as long as unhindered and free of stress. However already based on the principle of functions, remarkable resistance and clear losses come up. So probably that alternating current is moving essentially slower than light-speed.

Without any doubts: Alternating current (respective three-phase-current) functions well and is used with great success since many decades. Without these inventions, todays civilization would not be possible. However this technology shows great losses - unfortunately not to avoid or even judged to be normal. These uncontrolled radiations are unhealthy, because the procedure in general is not aether-conform. Nevertheless the advantages are considered more valuable. However by new sight of aether, probably new techniques could be developed, fitting better to the necessities and possibilities of that working medium.

Evert / 2011-08-30

09.06. Magnets

Miracle of Magnets

For young people the world is full of miracles. Most wonders lose the magic later on, however some remain unsolved till the end. The sciences present explanations, however many still remain 'wondrous'. The first experience with a compass is such a wonder: why does the needle show northwards all times, like being controlled by an invisible force? Later on one learns the compass is a small magnet-rod and the earth functions like a huge magnet-rod because embedded within a magnetic field and the geographic north-pole is a magnetic south-pole. Wondrously it's still a riddle how that could function with a red-hot iron core. However that's not relevant here respective that 'friction-magnetism' (analog to previous 'friction-electricity') is explained at earlier chapter 08.17. 'Aethervortex of Earth'.

The practical experiences with magnets unfortunately had negative effects for theories, not only of electro-technology and physics, but also concerning the general thinking-by-opposites. Magnets show clearly two poles and this dualism was raised to a general valid principle. It's assumed the existence of like und unlike stuff, attraction and rejection, plus and minus, all times just-likely this and just-opposite, a perfect symmetry e.g. by particles and anti-particles, up to super-symmetries - until finally to realize, just the 'system-violations' respective asymmetries arise the most interesting results. The common polarized thinking is too simple, too mechanical, too mathematical for the reality. There are no contrary extremes, there is only a more-or-less with smooth transition.

As an example, I was searching - many months and fruitless - for a pattern of aether-movements which would result a perfect sphere (e.g. because it's well known, the atoms are sphere-shaped objects). Finally when I was free to accept bumps and dents and pulsating swinging motions, I found solutions for that problem and unforeseen multiple motion-pattern in addition. Now here however the aether-movements are asked, which allow the appearances of magnetism.

Inner Magnet-Flow

At picture 09.06.01 upside at A a magnet-rod is drawn by longitudinal cross-sectional view, with its south-pole (S, red) and its north-pole (N, blue). The atoms of permanent-magnets are arranged by grids. So the aether-movements at the aura of atoms and at the spaces between the atoms are also ordered. These structures result an internal 'magnetic flow' which generally is directed from the south- to the north-pole (marked by thick blue arrow). There are good reasons for the assumption, that flow follows also previous rule 'in-drive-direction-left-turning' (marked by the black circle-arrows). The track of that movement thus is comparable with a left-turning staircase. Upside right is sketched a corresponding cross-section view at the south-pole.

All neighbouring aether must behave analogue. If that left-turning forward-motion exists within the material at the south-pole, also the Free Aether in front of the south-pole is stimulated to swing adequate. There exists a 'suction-effect' like at gases and fluids. These motion-structures within a 'tube' are also spreading backward. That's marked here by three blue arrows left side of south-pole. Analogue the motion-pattern does not end at the surface of the north-pole. There exists the same motion-pattern, i.e. also the movements of the Free Aether in front of the north-pole will take that ordered structure.

Outer Magnet-Backflow

A permanent-magnet indeed is comparable with a pump with simple blades, which is running counter-clockwise within a water-tank. At the inlet (south-pole) water is sucked in. Already some further back the flow starts 'twisting'. At the outlet (north-pole) that motion-pattern is pushed off. The ambient water (respective Free Aether) represents a resistance against these ordered movements. The 'jet' is redirected aside. At the south-pole a similar motion exists - and both flows as a whole build a perfect circuit.

That external back-flow is marked at the second row of this picture by the blue arrow B. Into direction of the flow (thus here from the north- to the south-pole) that left-turn is unchanged. Right side at the cross-sectional view, this turning movement is marked by the circle-arrow C. By that view onto the south-pole (thus contrary to the external flow-direction) that swinging movement appears right-turning.

At this picture only one thick blue arrow is drawn representing many 'magnetfieldlines' (which theoretic exist within all spaces of the material grid). Also the external back-flow here is marked by only two thick blue arrows. At reality, many most thin magnetfieldlines are running through the aether from north-pole back to the south-pole. Thus all around the longitudinal sides of the magnet-rod exists an

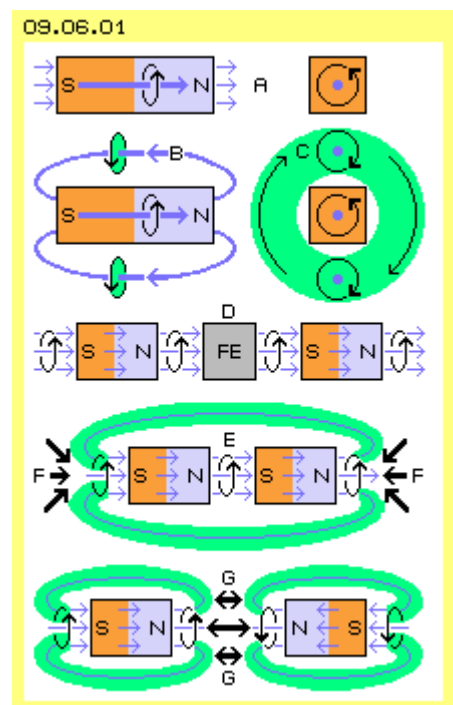

area of back-flow. Right side at the cross-sectional view, this area is marked by a green ring. All aetherpoints of this region are swinging parallel to each other, all left-turning into flow-direction. As a whole, this common swinging of numberless aetherpoints results the appearance of a general turning movements around the outer faces of the magnet-rod. The turning-sense is left-turning into flow-direction. By view into opposite direction, here viewing at the south-pole, that motion appears as a general right-turn.

Transit-Flow

An ordered flow within the gapless aether automatically forces neighbouring aetherpoints to move adequate. The ordered movement spreads into that direction, where the aether can take that motion-structure. At previous backflow this is the outside way from north- back to south-pole. Even simpler is the straight way from a north-pole to the south-pole of a second magnet-rod. This arrangement is sketched at third row of that picture at D.

The magnetic flow of the left magnet-rod is moving to the right magnet-rod, where its left-turning is unchanged. Here is drawn a rod of iron (FE, grey) between both magnets and the magnetic flow is also running straight through this material. The internal structure of iron can adapt the magnetic motion-structure, also alternating in both direction (as discussed some later).

Pushing instead of Pulling

At the following row E, both magnet-rods are positioned close to each other. The areas of the external backflow from north-pole right to the south-pole left is marked light-green. At the middle meet a north- and a south-pole. By common understanding now an attracting force comes up between these unlike poles - however common sciences can not offer any explanation for this function.

As often mentioned here, the Free Aether affects a general pressure onto all wide-ordered movements, thus also against this well structured magnetic flow. Within the magnet-rods and also within previous iron, that motion-pattern is protected. Also at that gap E, the Free Aether can not act disturbing, e.g. because the magnetic backflow exists all around that area. The general aether-pressure can show effects only at the open faces left and right side. So the magnetic field-lines are compressed from both sides. The material of the magnet-rods follow that pressure and thus they move closer, like marked by the black arrows F.

Shifting off

At the row below at this picture 09.06.01 the opposite situation is drawn. Here both north-poles of both magnet-rods meet at the middle. Like at previous example, also here the general aether-pressure is affecting at both sides and try to move together both rods. Much stronger however than the general aether-pressure is the effect of stress. Already before the bend-abilities of aether is strained to its maximum, inevitably must come up balancing movements to reduce the tensions. Here the aether is strong tensioned, because magnetic flows exit from both north-poles, thus in contrary directions and in addition the turning sense of both motions is conflicting.

Both flows affect mutual pressure, like marked by black arrows G. The flow is 'dammed up' and the material of both magnet-rods move back correspondingly. Only that balancing maneuver reduces the stress. Only by sufficient distance between both like poles, the magnetfieldlines can flow back to their south-poles unhindered.

It's ever astonishing, one can not completely press together the like poles of two magnet-rods by hands. Even harder to believe for many readers might appear, these strong forces are affected by that invisible aether-medium. As an answer only remains: what else? All forces finally are aether-movements. Just because the aether is indivisible and only one gapless substance, that absolute necessity of certain processes exists. Naturally it's common understanding, these effects are based on 'magnetic or electric fields' - however how could abstract 'fields' result real effects? Just for previous example of 'attracting forces' even no theoretic model for that function exists, especially as it should work through the 'nothing of vacuum'. The usual ideas and explanations are insufficient, no matter how often they are repeated and proclaimed. Aether is a totally real substance and certain movements within result firm results.

Different Forces

Since no concrete ideas for the function of aether-movements exist, commonly one simply works and calculates by abstract model of 'fields'. For example the magnetic fields between a north- and a south-pole are suggested to be homogenous. The attraction and rejection are assumed to be functions of these fields, so same forces with opposite vectors.

The real aether-movements however are most different and thus also the resulting forces. At the case of 'attraction' the magnets are pushed together from their ends by the general aether pressure. At the case of 'rejection' exists a much stronger necessity, caused by the contrary flows between like poles. So stress comes up within the aether and the relaxation of tensions is inevitable demanded. Finally appear huge forces because the aether can not be 'bended' above a certain limit.

Thus the forces between like poles are much stronger than between unlike poles. The effect between two north-poles differs to the situation between two south-poles. The 'magnetic flow' is forced to exit the face of a north-pole and each magnetfieldline at its location. A south-pole is 'sucking-in' that motion-pattern - however this is not urgent by same necessity. The south-pole can 'pull-in' also at faces aside or this motion must not be formed totally exact at the 'beginning' of the magnet-rod. So one may not simply follow cross-the-board formula for searching and developing aether-conform solutions.

Magnets via Current

At picture 09.06.02 upside left at A, a U-shaped conductor is drawn, where direct current DC is running from minus to plus. Around the conductor exists a left-turning motion as the result of 'magnetic induction', marked by the blue circle-arrows. The conductor can also build loops, resulting a coil like sketched upside right at B. Looking into direction of the current, the coil is winded left-turning. All left-turning motion inside of the coil result a magnetic flow, which here is directed from left to right side (marked light-blue, see dark-blue arrows). Analogue to previous magnet-rod, magnetfieldlines are directed back outside around the coil (marked light-green, see dark-green arrows).

If an iron-rod (FE, grey) is added in the inner magnetic field, the field-lines are running through the iron. While the current is running, the iron-particles (by parts) become oriented according to the magnetic field. The magnetization of the coil-core schematic is sketched at this picture below left at C. The magnetization is not permanent. If the coil is driven by alternating current AC, the direction of current changes periodical and thus also the magnetic field.

Finally if a strong direct current DC (thick black arrow, right side at D) is pressed through the coil, the orientation of the iron-particles is fixed so strong, a permanent magnetization is achieved. Normally not all particles are perfectly ordered. So the magnetic fields at the poles indeed exist by separated 'magnetfieldlines'. Permanent-magnets build by material of 'rare earths' are stronger by hundreds. There the magnetic flow might spread really the whole face, i.e. all aether there might swing parallel to each other in total.

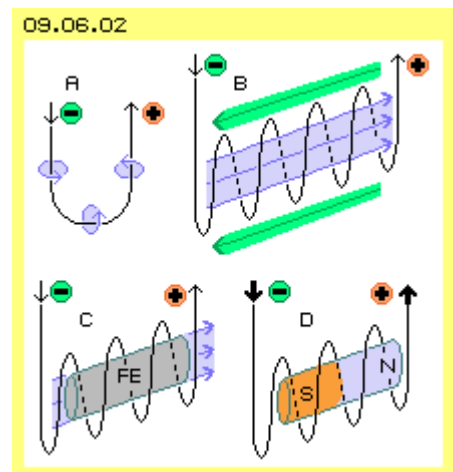

Coupling Space-Energy

Over and over again it's discussed, whether a permanent magnet is a 'perpetuum mobile'. For example, previous magnetization needs strong DC only for short moment and the generated permanent magnet provides forces 'lifelong'. The law of energy-constant seemingly is injured. So it's suggested, the magnets would tap any kind of 'space-energy'.

The term 'energy' is used by so much meanings, so by itself got lost any meaning. At subjects of physics one can replace 'energy' by the term 'motion' - and as only the aether really exists, energy is nothing else than aether-motion. Really all the aether is permanent moving, so unlimited energy exists. Because the aether is a gapless substance, the motions never can come to a standstill. However the chaotic narrow motions of Free Aether are without effects (besides the resulting permanent general pressure affecting onto all well structured motion-units and thus e.g. stabilizing electrons and atoms, and Free Aether naturally is involved in electric appearances).

In general however, usable forces can come up finally from an ordered aether-motion. At natural magnets the internal structure of the material (by chance) produces an ordered motion in shape of the magnetic field. The general motion-pattern is that 'forward-and-left'. Combined with iron-parts or other magnets automatic come up these force-effects which commonly are called attraction respective repulsion. As discussed upside, the real cause however is the general aether-pressure onto ordered motion-pattern, here onto the magnetic fields.

The force-effects of ordered aether-movement occur not only at these small magnets. The structured forces in principle are working infinite long - just because the movements of aether can not be stopped. For example, the whirlpool of the sun permanently performs a centripetal force (against the centrifugal force) and for millions of years thus the earth is drifting around the sun. However the structure of aether-motions can be disturbed (e.g. by comets or at magnets by heat). At the other hand, one can organize well structured aether-motions, e.g. by previous magnetization or as later chapters might show. By sure, the result will not be a Perpetuum Mobile - because the energy of aether is omnipresent and generating usable forces demands only a skilled organization.

Remark: Magnetic Field left-turning

An important remark in 'own concern': in some earlier chapters I wrote, the magnetic field might be right-turning. At these times I assumed all aether would be left-turning in general. A magnetic field has effects only within a limited area and magnetfieldlines are pressed back at most short way. So I deduced the left-turning aether compresses and even eliminates the right-turning fieldlines. This was wrong.

It's well known, the electric current induced a left-directed magnetic field. Just this is applied at previous magnetization. So the particles must adjust accordingly at the production of synthetic magnets. A natural permanent-magnet shows same effects like a magnet-field produced via current. Thus also the motion-pattern must be likely: 'into drive-direction left-turning'.

No wide Flow but narrow Swinging

Terms like 'flow, flowing, running' etc. were often used at previous descriptions of aether-movements and the behavior of aether was compared with gases and fluids. The real movements of the real aether however are bound to other necessities. The aether is gapless and anywhere of likely density. Aether can not move far distances. It can only swing at relative narrow space. Above this it's necessary, one locale shifting of aether is compensated by a contrary movement, e.g. like both layers of a 'double-crank' function. Motion-units are only stable, if all mutual removals perfectly fit, like e.g. by that synchronous swinging all around of the sphere-shaped electron.

Like shown upside, photons are racing through the space by light-speed. However no 'particles' nor aether are running through the universe. Only the motion-structure is forwarded within the (nearby stationary) aether. Like this, e.g. also the 'spindle-pattern' of electric current wanders along the surface of a conductor. Or these 'vortex-spindles' of charge stand stationary and upright swinging above a surface.

Analogue is the situation at the 'magnetic flow', where in reality nothing is moving forward. Opposite: this motion-patterns 'stands stationary' between the magnet poles. It exists inside the material respective within the core of previous coils. It exists between the poles of magnets and also the magnetfieldlines stand like shells along the outside faces of magnets. At picture 09.06.03 is drawn a section of the magnet field within free space between the surfaces of a north-pole (N, blue) and a south-pole (S, red).

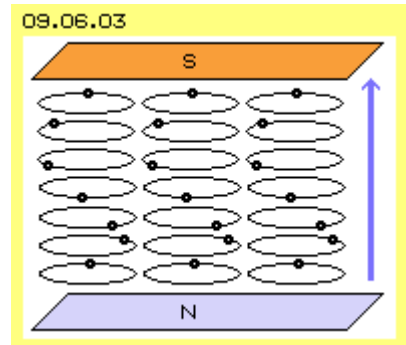

There are marked seven aetherpoints (black) upside each other and each two neighbouring aetherpoints aside. All points are swinging parallel to each other, each at its circle-track, each left-turning. In order to achieve a local balance of aether-volumes, the points from bottom up are 'time-shifted'. The points most upside and most down momentary are at the background (respective at their 12-o'clock-position). The point at the middle row momentary are at the foreground (respective at the 6-o'clock-position). The points between are each shifted by 60 degree.

The motion-process is visualized by this animation - which at first might look even confusing. When looking concentrated at one point, obviously it's only circling at its round track. All neighbours aside are swinging parallel. Also at the vertical direction, all points are swinging by likely speed. From bottom up, they are only some later at their tracks.

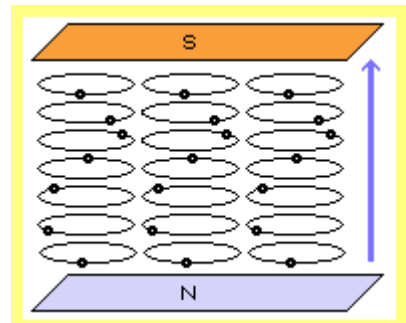

The connecting-line between vertical points builds a spiral curve. Like the points are only turning around at their level, the connecting-lines are simply turning within the space between north- and south-pole. Nevertheless the impression comes up, anything is spiral-upward moving. This 'seeming appearance' corresponds to the direction of magnetic flow: coming out of the face of the north-pole and wandering into the face of the south-pole, like here marked by the blue arrow.

Thrust-Effect

The upward-movement of the spiral does not exist really. This is only the visual result of time-shifted swinging at different levels. Nevertheless a real affect can come up, if other motion-units enter this area of stabile motion-pattern.

Each aetherpoint of its circle-track 'pushes' its sideward neighbours in each corresponding direction. The aetherpoints at the middle level of previous picture 09.06.03 are momentary at the foreground (6-o'clock) and are moving further right side. If aetherpoints of an other motion-unit (e.g. of an electron or a material particle) exist at the right side, they are affected by some thrust toward right side. The aetherpoints at the level upside of, come some later at this position and thus also their pushing impulse. As a whole, that 'foreign body' is affected by a diagonal-upward thrust.

At picture 09.06.05 left at A the swinging of the aetherpoints of a 'magnetfieldline' is shown once more. Here is also drawn the vertical connecting-line in shape of that blue spiral. Below at the middle at C, a section is drawn and the general left-turn and the seeming upward-motion are marked by blue arrows. The previous mentioned diagonal thrust is marked by blue dotted curve, which eventually could affect a 'foreign' motion-pattern.

Upside right at B is drawn a grey conductor, where a 'current is flowing' from minus to plus. Therefore comes up a magnetic environment (light-green) with movements practically identical with previous magnetfield-pattern: forward into current-direction and left-turning, like marked by the spiral curve. Below right at D again a section is drawn and the movements are running analogue to the previous ones: a left-turn combined with a forward-motion (see thick red arrows). Again a thrust-affect could result (see dotted red curve) onto 'foreign bodies'.

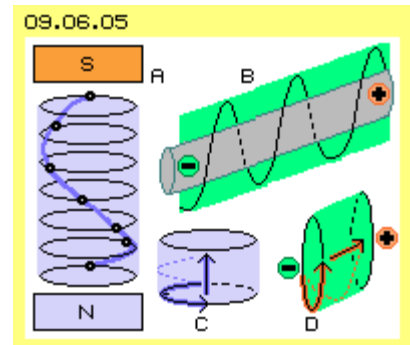

Similar however different

So at subject of electro-magnetism are combined two appearances of similar motion-pattern. But still exist grave differences. An electron is a basic unit of electricity. It's a sphere-shaped complex of aether-vortices, which are rather stabile as a whole. Towards outside the electron has an aura of balancing motions to the Free Aether, thus is enclosed within an 'electric field'. Electrons are easy to produce, like upside example of the velvet-carpet did show. They are generated in huge numbers e.g. by 'friction-electricity' at storm-clouds.

Many electrons there are moving into likely direction and they leave a trace within the aether. Within the tube-shaped 'slides' they become transferred into a common swinging, which occasional is called 'space-charge' or even a 'plasma'. When the lightning strikes the ground, that mixture of extreme motions produces the 'electric charge' which is spread over the ground all around by the general aether-pressure.

The characteristic of charge respective static electricity are vortex-spindles, standing and swinging parallel besides each other, showing from the surface outward. This 'electric field' sticks at a material surface respective this ordered flat motion-pattern is pressed on the face by the general aether-pressure. Nevertheless weak extensions of the vortex-spindles reach far out into the space. The 'stationary' charges with their internal movements practically build an energy-stock, e.g. also to store temporary by a capacitor (see later chapters).

The electric current is also based on vortex-spindles, which however are directed along a conductor surface. They are swinging within a relative small ring-shaped area between the outside atoms of the conductor, mostly however within the common aura-shell around the conductor, and the atoms of any isolator-cover. These thin spindles can easy move in longitudinal direction, because at front sides the general swinging of the aether must increase to a wider radius only by minimum size (and the rear ends of the spindles are shifted forward by the Free Aether). This flow can be generated (see following chapter), it can be dammed-up (by any kind of switch), finally it can be 'consumed' (in order to achieve certain usage), can flow back to the generator or into the ground. This current can flow along conductors by separated impulses, also in alternating direction. When using DC, the separated spindles can 'melt to endless long threads'.

Only that 'flowing' results electro-magnetism, as the swinging of electric current by itself generates a common outside motion around the conductor. This aura is the 'induced magnetic field'. The 'electric field' is forward directed and only that narrow ring-shaped area of the original current-motion is involved by these thin vortex-spindles. Even that movement is most intensive, it is bound narrow to the conductor. It's not dangerous to manually hole e.g. a 220 V wire which is covered by only millimeter-thin isolator.

Quite different behaves the induced magnetic field, as it reaches far out into the environment. Obviously that swinging-pattern can penetrate the isolation and also other materials - and practically no protection exists against the magnetic fields. So around a 'live' conductor inevitably exists a magnetfield all around. This field accompanies the current-impulse along the conductor. The magnetic flow can be concentrated, e.g. at the core of previous coil (later discussed in details). The generated magnetic field decreases as soon as the current is stopped.

The motion-pattern keeps constant at permanent magnets. Here also the pattern keeps stationary, it's practically 'anchored' at the surfaces of poles (or iron-parts between, and also within the core of coils). So the movement-pattern of natural magnets, permanent magnets or magnetism induced by current are rather similar. The important difference exists on the bond: at the one hand onto the material, at the other hand at the flow of a current. Next chapter will show some interactions between both appearances.

Evert / 2011-09-09

09.07. Magnet and Current

Diagonal Thrust

Picture 09.07.01 upside shows three 'magnetic fieldlines' between north-pole (N, blue) and south-pole (S, red). The aetherpoints (black) from bottom up are turning 'time-shifted' at their circled tracks. The vertical connecting-line between these observed aetherpoints builds a spiral (thick blue curve).

Now here also the aetherpoints aside each other are some later at their tracks, i.e. the three columns as a whole are 'time-shifted'. From left towards right come up following situations. Here e.g. at left border the blue arrow A marks how that edge seemingly 'slides' upward. Also at the right edge is marked by arrow B, how that 'wave' is moving upward (watching the columns from left to right). Really existing are only motions at pure circled tracks at the diverse levels. But still the follow of time-shifted movements appears like a diagonal upward directed thrust. Each magnetic fieldline affects a 'spiral-turning flow' from north- to south-pole.

Left-Turning Current

At the second row of this picture at C is drawn a conductor-wire (grey). A current is running along from left to right side (so from minus to plus, see red arrow). Every current is embedded within a magnetic field (light-green), showing towards left (all times by view into direction of current). Thus also around a live conductor exists a spiral forward directed motion.

Right side at the picture at D schematic is drawn a cross-sectional view through the conductor. Around the wire (grey) the current is running within a thin ring-shaped layer (red). Outside of the current-by-itself, the magnetic field (light-green) reaches far out into the space all around. By view on the minus-end of the wire, the magnetic field is left-turning (see red arrows).

Current through Magnetic Field

At third row at E now a situation is shown, where this current-carrying conductor reaches cross through the magnetic field, here from foreground to the background. This wire is a 'disturbing foreign body' for the magnetic field. The aether-movements of blue magnetfieldlines collide with the movements of the light-green magnet-field F. Most important are the fieldlines which 'scratch' against left and right edges of that foreign body.

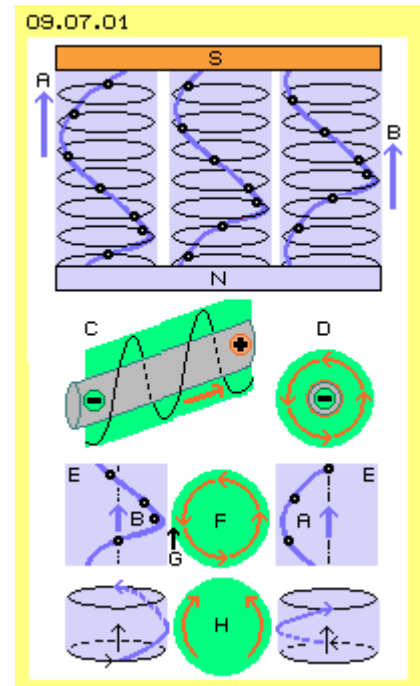

At right side previous edge A is drawn, which there is 'screwing upward'. This side shows relative few problems, because both movements are upward directed (see blue arrow A and red arrow F). At left side, previous edge B interacts with the light-green magnet-field. This side is problematical, because there the downward-movement around the conductor (red arrow F) is opposite to the upward-movement of the fieldline (blue arrow B). There the magnetic field around the conductor is affected by a counter-pressure (G, black arrow).

Also a pure mechanical comparison shows the problem clearly. Both magnetic fieldlines work like thread-rods (blue), both left-turning around vertical axis, like sketched at this picture below at left and right side. The magnetic field of the current then is comparable with a gear-wheel (H, light-green) with horizontal axis. The gear-teeth are build diagonal, so the right thread-rod produces the necessary left-turning of the current-gear-wheel. This interlocking however does not fit to the necessary motions at left side. There would come up 'transmission-trouble' respective here within the aether comes up stress.

Swerve aside

At picture 09.07.02 upside left at A once more is drawn the situation of current-carrying conductor within a magnetic field. Previous counter-pressure here is marked by three black arrows. As discussed upside, the magnetic fieldlines between the faces of north- and south-poles are 'stationary bound' and thus relative 'rigid'. If this motion-pattern would swerve aside, the swelling would result wider surface towards the Free Aether. However the general aether-pressure pushes the magnetic fieldlines all times into that direction, where the way between poles is most short.

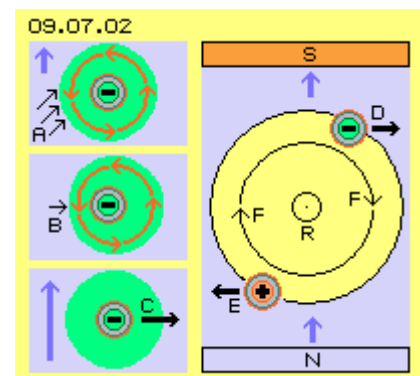

Opposite, the magnetic field around the conductor is easier to move, because it's anyway shifted forward along the wire. The counter-pressure A thus is affected by less resistance, when the green magnetic field is compressed little bit, like marked by arrow B. This field now is no longer

concentric to the wire, thus inside of comes up tension. If the wire is movable, the wire is pushed towards right side, like marked by arrow C. This is the cause and the process, why current-carrying conductors within a homogenous magnetic field are affected by the 'Lorentz-Force' as a sideward thrust.

At this picture right side, a rotor (R, yellow) is drawn by cross-sectional view. Upside at D is drawn a conductor, where current is running from foreground backward. The Lorentz-Force pushes that wire towards right. Below a E a conductor is drawn, where current flows into opposite direction. Its enclosing magnet field is right-turning by this view and the Lorentz-Force presses that wire towards left side. Both thrust-forces (see black arrows) result a turning momentum at the rotor. However that thrust is affecting only each half turns, like marked by arrows F.

DC-Motor

A steady turning of the rotor is achieved if the current-direction periodically is changing. The principle of that Direct-Current-Motor is shown at picture 09.07.03, left side by cross-sectional view and right side by longitudinal cross-sectional view through the rotor (R, yellow). Previous wires are connected at the rear side of the rotor and build a conductor-loop (LS). The upside section of the conductor is marked green. There the current flows from the foreground back, at longitudinal view from left to right. The below section is marked red and there the current is running from the background forward, at longitudinal view from right to left side (see arrows). Instead of that single circuit could be arranged many loops, building a coil.

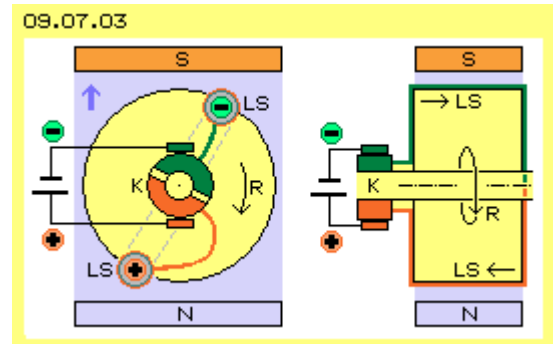

The change of current-direction is done by a 'commutator' (K). It exists by two half-circles (marked green and red), each connected with the ends of previous wire (however isolated mutually and versus the shaft). Via slide-contact (e.g. in shape of carbon-brushes) the current is fed from a DC-source. Here the direct-current all times is guided to the conductor-section which momentary is positioned upside and guided back all times by the section momentary positioned below.

At textbooks for example it sounds like this: "A wire-loop within a magnet field is affected by a pair of Lorentz-Force and a mechanical turning momentum $M = \dots$ comes up. The turning moments adjusts the wire-loop that kind, the perpendicular-face is moved parallel to B. This is the basis for electric motors". Everybody knows that well and everybody has seen the simple model of an electromotor. However in reality are working only mini-motors by this principle, effective devices are based on other principles (see later chapters). Nevertheless that Lorentz-Force exists, which was and still remained 'wondrous'. Finally previous considerations, based on existence of a real aether with characteristics claimed here, prove a logic explanation of that electromagnetic 'wonder'.

Reversal Conclusion

At textbooks often is stated cross-the-board: "a generator is working by same principle like a motor, only by reverse affects". Here this would mean, previous device should produce electric current, if the rotor is driven mechanically. This is analysed by picture 09.07.04. Upside left at the picture once more exists a homogenous magnetic field (light-blue) between the north-pole (N, blue) and the south-pole (S, red). Within the magnetic field a rotor (R, yellow) is turning clockwise. At the rotor is drawn a conductor (grey) at four positions which it will take during the rotation of the rotor. Right upside at the picture are drawn three situations in details.

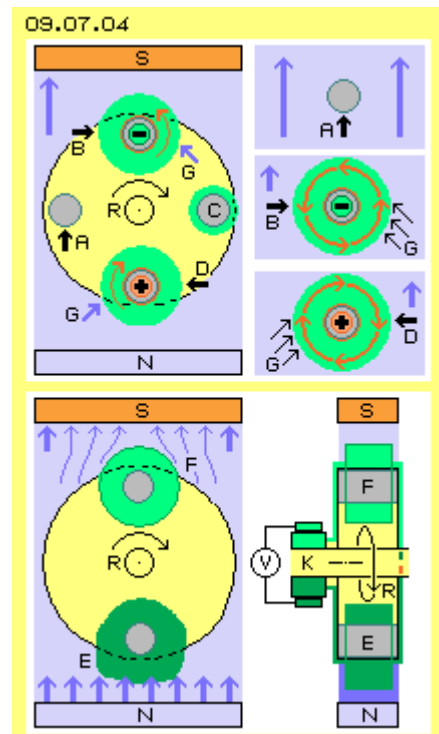

At A the conductor is moving upward within the magnetic field. By common understanding, no interactions exist at this process. The aetherpoints simply are swinging at their levels and their circled tracks. They also penetrate the copper-material of the conductor. The aether around the conductor simply swings some to and fro, without building a turning layer around the wire.

No Current

Quite different is the situation, when the conductor crosses the magnetic fieldlines, like marked by arrow at B. A counter-pressure (G, see arrows) comes up at the right side, which forces the aether into left-turn around the conductor. This would correspond to a flow from foreground backward. Unfortunately however the aetherpoints of the magnetic field come from the background forward. The spiral connecting-line respective previous 'thread-rod' pushes the aether upward, however directed to the foreground. Thus no electric flow can come up.

The advancing of the conductor affects a pressure onto the magnetic fieldlines. There will come up vortices to reduce the tensions. However the induced vortices have no clear structure. These vortices can calm down, when afterwards the conductor is moving down at C, thus parallel to the fieldlines and thus without interaction.

At D the conductor crosses the fieldlines once more, in opposite direction. Now the counter-pressure (G, see arrows) come up at left side, forcing the aether right-turning around the conductor. A corresponding current would flow from the background forward. However at this edge the aether is pressing backward. So as a whole, this arrangement can not produce well structured current, but only temporary whirls.

Induced Voltage

Below at this picture 09.07.04 once more is drawn the construction of previous DC-motor, left side by cross-sectional view and right side by longitudinal view. The rotor (R, yellow) is right-turning by mechanical drive. Again a conductor-loop is installed at the rotor, where momentary a section E is positioned below and a section F is positioned upside. Again a fix connection exists between the wires of the conductor-loop (or a coil) and the two half-circles (light-green and dark-green) of a commutator K. Both halves of the commutator are connected with a voltmeter V via slide-contacts.

Based on many 'classic' experiments the 'law of electromagnetic induction' was formulated. In the given case is stated: "If a coil is turned within a permanent magnetic field, one can observe the appearing and disappearing of an induced voltage, two times each revolution". So this voltmeter will deflect twice during one revolution of the rotor respective the conductor-loop within the magnetic field. This is 'valid law' - even one does not know why and how that effect really occurs.

Asymmetries

Previous DC-motor produces mechanical turning momentum, if current is fed. If however the same machine is driven by mechanical input, it does not produce current - but only some voltage is generated. Voltage is a 'potential' which corresponds to the difference of charge-intensity. So strange enough this device produces charge of different strength in both sections of the conductor-loop. By view of the aether and based on previous considerations, this 'phenomenon' might be based on two causes: the difference between magnetic north- and south-poles and the in-homogeneity of the magnetic field.

As mentioned upside, the magnetic fieldlines at the surface of the north-pole are strong bound at their source. The internal twisting aether-movements must exit exactly at their locations, in shape of a spiral motion-pattern, into the environment, by their original shape. At this picture this fact is marked by thick blue arrows upside of the north-pole. If a 'disturbing foreign body' is crossing near along that surface, strong whirls within the aether around the conductor will come up. This 'charge in shape of strong aether-vortices' is marked by dark-green area at E.

At the surface of the south-pole less necessity exists by 'sucking-in' of suitable motions. Like at whirlwinds, the 'suction-trunk' can twist and wind around. In addition, the disturbances near the north-pole damaged the magnetic fieldlines, so near the south-pole they are no longer in their original precise shape. At this picture this fact is marked by smaller and curved blue arrows below the surface of the south-pole. If the conductor crosses that area of motions less ordered, at the surface of the wire will stick less vortices all around. This weaker 'charge' of the conductor at the south-pole is marked by the light-green face.

Few Charge-Difference

Common sciences can not explain wherefrom that voltage-difference should come. It must be charge-differences, however here is no source for charge-carrier. These whirls are not ordered so good, already a 'magnetic field' could come up. It's only just normal aether around the conductor. The appearance of 'charge' only comes up because these whirls are impressed at layers near the surfaces. An electric flow finally comes up exclusively, when the Free Aether with its general aether-pressure flattens that accumulation of intensive aether-movements.

At both sections of the conductor-loop these vortices-layers show different height. So the high charge-density (dark-green) is pressed towards the low charge-density (light-green). So along the wire (or the wires of a coil) at the rear end of the rotor, an exchange of charge occurs. At the front-side of the rotor (via the commutator) thus only the remaining rest of voltage is measured by the voltmeter.

So probably much higher voltage is generated within the conductor-loop than the voltmeter indicates. At the other hand, the distance between north- and south-poles is rather far at this construction. In addition the magnetic field is too in-homogenous for generating a well ordered motion-pattern. That's why this conception is not really effective and merely used for production of voltage.

Charge-Catcher

Picture 09.07.05 upside left at A shows the 'classic' graph of induction-law concerning a conductor-loop within a magnetic field. Such loops respective coils are conventional elements for explaining electric 'phenomena' and laws. Above this and as a rule, most electric devices function by closed circuits. So probably only an uneducated

layman could produce the following considerations (and at the very moment I really do not know whether that idea is common practice or totally new).

Clear might be the fact, the charge is generated only at these sections of a conductor-loop, which momentary are crossing the face of a pole (preferably a north-pole). Charge however needs no closed circuit. For example, charge can (temporary) be stored also at the surface of a metallic-sphere or a capacitor-sheet, where only one wire is necessary. So the connection between both sections is not necessary. That part of the loop is even damaging because it allows an exchange of voltage without useful effect.

The logic consequences are sketched at this picture upside right at B. The part below of the loop is cut off. Only the remaining two tips of wire now reach into the magnetic field (light-blue) between north- and south-pole. These constructional elements should be build as stabile metallic bolts or thin tubes. I call these new elements the 'charge-catcher' LF. Like previous loop now both bolts are turning within the magnetic field. If momentary a bolt crosses the north-pole, it will get covered with high charge (dark-green). The other bolt same time crosses the south-pole and will catch less charge (light-green).

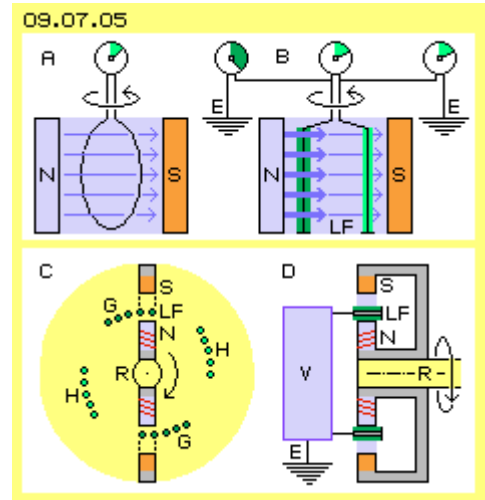

If both bolts are connected with a voltmeter, it will indicate voltage. Because no longer exists an exchange between both bolts, the voltage will be stronger than at the 'classic' wire-loop (at previous A). Quite upside right a voltmeter is installed between right bolt and the earth E. In comparison with the 'normal-charge' of the earth, the voltmeter will show some voltage, because the right bolt did catch some charge by crossing the (somehow disturbed and weakened) magnetic field of south-pole. The whole strength of generated charge however indicates a voltmeter between the left charge-catcher (dark-green) and the earth.

Charge-Generator

If loops or coils are used at rotating systems, the crossing of magnetic fieldlines occurs two times at each revolution, resulting alternating current. This 'one-arm' charge-catchers are crossing the magnetic field likely, however the charge can flow off only into one direction, thus they deliver direct current all times. Below at picture 09.07.05 schematic is sketched a corresponding conception, left side by cross-sectional and right side by longitudinal view. It shows the generally preferred version of devices, where the current-carrying conductor is installed stationary within the stator and the magnets are arranged within the rotor.

At the rotor-shaft (R, yellow) two horseshoe-magnets are installed (at this example). The north-pole (N, light-blue) is positioned inside, the south-pole (S, red) some outside of. The magnet are fed by a coil, which is served with DC (by common techniques, here not drawn). This current is running all times into same direction. Within the iron-core of the magnet occurs no reversal of polarity. So practically results a permanent magnetization. The strength of the magnetic field between the poles is intensified only by short current-impulses.

The rotor of this example is build only by a cross-beam with these two magnets. Naturally several magnet-beams could be installed. However between the magnets should exist sufficient distance. The yellow face left side at the cross-sectional view thus is no rotor-disk but marks only the turning-area of the magnet-beam.

The charge-catcher (LF, green) are reaching from left side (at this picture) into the space between north- and south-pole. Here as an example are drawn each five bolts at four units. During the rotation, the magnetic fields are crossing the stationary charge-catchers. The distance of the faces between north- and south-pole is small. So strong whirls are achieved at the surfaces of the charge-catchers.

Current-Flow by Aether-Pressure

Important now is the free space towards next group of charge-catchers. At the one hand, the magnetic field can calm down and restructure until the horseshoe-magnet next time is fed by previous DC-impulse. At the other hand this space- and time-section is necessary for useful work of the Free Aether.

The charge exists by aether-vortices more or less ordered around the surface of these bolts. Against that 'wide-range motion-mess' stands the narrow trembling of Free Aether. The resulting aether-pressure 'wants to eliminate that disturbance'. It presses down the vortices at the conductor, until a balance of charge-density is achieved. There the law 'in-drive-direction-left' is valid. The initially unordered vortices are transformed into a ordered left-turning magnetic field around the conductor, which thereby becomes current-carrying.

At previous longitudinal cross-sectional view is sketched only schematic, how the generated direct-current is guided to a consumer (V, blue) and finally is running into the earth (E). When ever a magnetic field crosses a

group of charge-catchers, a current-impulse comes up. The pulsating currents can be transferred into useable shapes by known technology, e.g. also in alternating current. Naturally the number of magnets and (groups of) charge-catchers can be arranged within that machines as one likes it, e.g. for generating three-phase-current.

Fluid-conform Shapes

The previous machine thus at first produces only charge, which by a second step is transferred into current. Naturally it would be preferable, if immediately the flow of electric current could be achieved. This question is analysed at picture 09.07.06.

Upside left at A is drawn an alternative arrangement. Around the shaft of rotor (R, yellow) the horseshoe-magnets are installed that kind, the gap between north-pole (N, blue) and south-pole (S, red) are open towards outside. The charge-catchers (LF, green) from outside are reaching into the space between the poles. At B the room-of-rotation of the magnets again is marked yellow. At left half of that face, diverse green bolts reach into the gap in radial directions. The connection to the consumer (V, blue) here is marked only 'symbolic'.

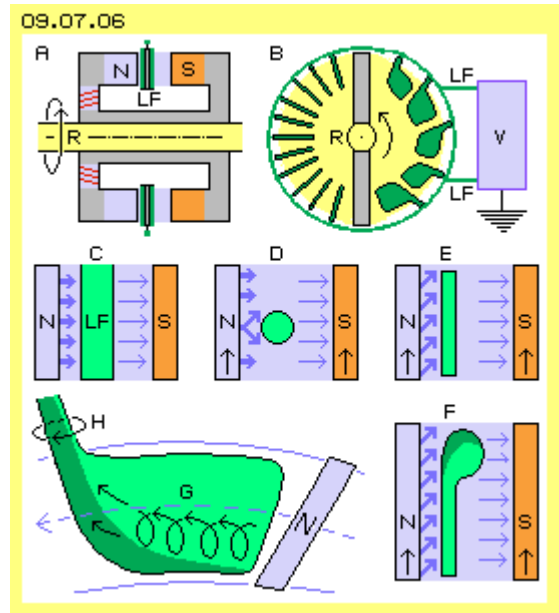

At C this arrangement is drawn by larger scale. Strong magnetic fieldlines exit from the face of north-pole (marked by thick blue arrows). The bolt (LF, green) should be near to the face of north-pole, however the distance to south-pole could be some longer. At D this situation is sketched by cross-sectional view at a round bolt. The vertical arrows show how the poles are moving relative to the stationary charge-catchers (here towards upside). There is also indicated a problem, as the magnetic fieldlines can 'slip-off' at both sides of the round bolts (see split arrow). There comes up only such disordered whirls, like mentioned upside.

At E is drawn a plane face instead of the round bolt. The magnetic field can 'stick' at this surface better ordered charge-vortices. One can imagine the left-turning movement of the magnetic field functions like a 'wobbling disk' (of a sander). As these movements are passing the charge-catcher, they draw a 'garland-shaped' motion-pattern at the surface. The following magnetic fieldlines push that pattern forward, like marked by the diagonal blue arrows. Only the front-side (showing to the north-pole) is important. At the backward face (showing to the south-pole) the 'disturbed' fieldlines can draw only weaker vortices.

If finally an electric current should flow along a round conductor, the according aether-environment must turn left. Previous flow along the plane face thus must be transferred into left-turn. Therefore at F the charge-catcher is rounded at its frontside edge. The magnetic fieldlines affect a thrust, which spiral 'screws' from north- to south-pole. This motion pushes the generated charge around that curved edge..

At G a sideward view onto that charge-catcher is drawn. The plane parts of the face are marked light-green, the curved areas are marked dark-green. Finally they merge smoothly into a round conductor H, which is inclined some forward (in turning sense of rotor). Resulting is a shape like a 'golf club'. Upside right e.g. five such charge-catchers are drawn (alternative to the simple bolts of left half there). The new shape is deduced from the simple bolt, which is some inclined forward and below is some bended backward. In addition that bolt is accomplished by a little 'flag' in shape of the plane face.

Below at the middle of this picture the surface of the north-pole (N, blue) is drawn and its track is marked by blue dotted circle-arcs. At the green 'golf-club' now is marked the 'garland-trace', which results from the circle- plus forward-motion of the magnetic fieldlines. Automatic comes up a forward-stroke motion-component, like marked by the arrows. The face of the magnet should be long-stretched in radial direction and arranged some diagonal. So that diagonal-upward affecting thrust becomes stronger. Finally the charge is pressed left-turning along the conductor H (see arrows). As soon as the magnet has passed that charge-catcher, the Free Aether starts working, pressing down the piled-up (and already left-turning) aether-vortices and pushes the current-flow forward along the conductor-wire.

Current-Generator

It might strike some readers as strange, the shape of constructional elements should be important for electric current. A comparison with fluid-technology might help. The particles of air are moving in chaotic manner, based on normal molecular movements. For example is demanded some power to push an air-plane forward. It demands only a certain shape of wings to organize an ordered flow, which finally produces a much stronger force for lifting upward the plane (for details see e.g. chapter '05.04. Lift at Wings').

Here already exists an ordered flow in shape of the left-turning magnetic fieldlines (which are available by permanent-magnets practically without costs or demand only few input of current-impulses). In addition the rotation of the rotor demands some power-input. The drive forces however are only necessary to overcome the mechanical friction (because here don't exist electromagnetic contrary effecting forces). The combination of both motions result a 'swinging-with-stroke-component' (see earlier chapters). This must be shifted and twisted accordingly along the curved surfaces (practically without costs analogue to fluid-flows, here affected by the general aether-pressure). Finally results a left-turning field within the space around the conductor and that generated magnetic field results the flow of electric current direct at the surface of the conductor. The strength of these currents depends on the construction of the machine, e.g. concerning the number of charge-catchers and magnets and the rotation-speed of the rotor.

Previous discussed Lorentz-Force exists without any doubts, however is usable at electro-techniques only for 'toy-motors'. If conductor-loops are turned within magnetic fields, the laws of induction are valid without any doubts. Previous conception shows some different characteristics for most effective realization of the effecting forces. Probably not only 'toy-generators' might be possible for production of electric current by these ideas.

Evert / 2011-09-15

09.08. Unipolar-Generator

Unknown Territory

It was a hard job to develop the idea of that 'golf-club-generator' at previous chapter. It's not usual to cut conductor-loops or -coils in two every day. So the description of new functions was somehow difficult. Probably that principle will clear up by a second starting point: replacing the coil by a disk. Michael Faraday started diverse experiments already in 1831, resulting strange effects and finally the famous 'Faraday-Generator'. This machine produces continuous DC without the usual (two-pole-) commutator and thus is also called 'Unipolar-Generator'. Today these devices are also called 'N-Machines' because they probably show n-fold effect. At the internet many discussions are running around these terms.

Also today some appearances still are 'wondrous'. For example it's an open question whether these machines are a 'perpetuum mobile'. Faraday is known as an outstanding experimental expert and theorist, however that generator-type merely is noticed in official textbooks. So the unipolar-machine still is a 'scientific white spot'. Now here that problem is analyzed exclusive by view of the aether. At picture 09.08.01 schematic is drawn the general principle, upside by longitudinal- and below by cross-sectional view through system axis.

Conductor-Disk instead of Coil

Left and right side are drawn two horseshoe-magnets, each with a south-pole (S, red) and a north-pole (N, blue). Either permanent- or electro-magnets (EM, grey, energized by DC) are usable. A disk-shaped rotor (RO, yellow) is turning within the magnetic field. The rotor is fix mounted at a shaft. The rotor and the shaft are build by electric conducting material. A sliding contact (SK, green) glides along the surfaces of the shaft and a second contact slides along the rim of the disk. The faster the rotor is turning, the stronger is the voltage between both contacts, like shown by a voltmeter (VM, dark red).

This effect corresponds to the induction-laws: one can imagine the disk existing by many conductor-wires arranged radial. Each 'wire' crosses the magnetic field. Based on Lenz-rule, a current is generated within the conductor. At a flat conductor, the current runs circling around, building so-called 'vortex-flows' (WS, 'eddy-currents', marked by some dotted curves). The magnet-field of induced circling flow by itself hinders the movement of the conductor.

So mechanical drive is demanded for running that machine as a DC-generator. Opposite, this principle is used as 'eddy-current-brake', e.g. at trains, lorries or busses. The 'recovery' of electric energy via mechanical brake-energy is most important at momentary development of electric cars.

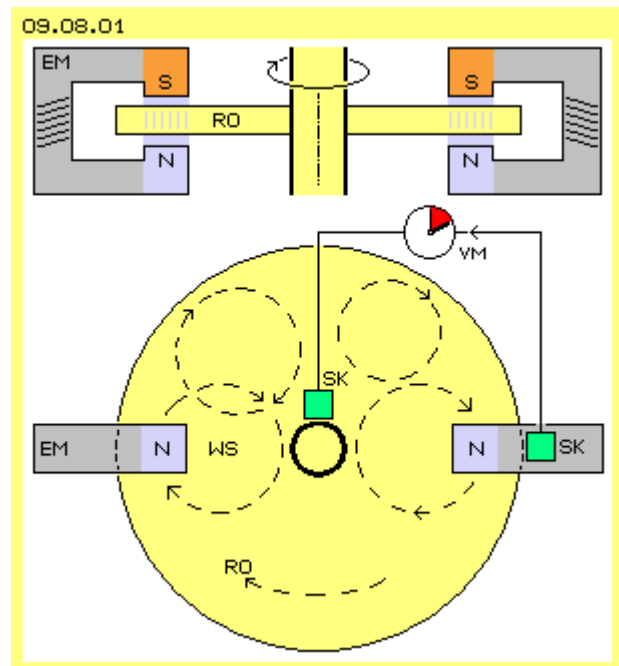

Over-all Magnet-Disk

The more horseshoe-magnets are used, the more DC that machine produces. At extreme case, the magnets could be installed all around. Already Faraday (and many contemporary researchers) made experiments with disk-shaped permanent-magnets, where the rotor in total was turning within an axial oriented magnetic field. This conception is sketched at picture 09.08.02 left side at A.

Below is drawn a disk-shaped permanent-magnet (PM) with its south-pole (S, red) and north-pole (N, light blue). The rotor (RO, yellow) is turning at the magnetic-field upside of the north-pole. Again two sliding-contacts (SK) are installed outside at the rotor and inside at the shaft. The voltmeter (VM, dark-red) shows only few voltage. An ammeter (AM, dark-red) however shows strong current, available for a consumer respective load (L, blue).

Low Voltage, strong Current

As an 'average citizen' I only know, normal wall-sockets have 230 V voltage and can take a load of maximum 3500 W because the fuse limits the strength of current to 16 A. In comparison is pretended, even unipolar 'toy-devices' show voltage of only few mV, nevertheless produce currents of 30 A. Already hundred years ago, machines were build with 300 kW, 500 V and 600 A. Currents for electrolysis-installations usually need only 6 to 40 V however strengths above 6000 A. Up to 300000 A are claimed for machines producing 'military benefits' - for usual unlimited nonsense.

Common current-generators produce voltage in changing strength and direction. Only by a second step comes up that flowing and finally via commutator results the (pulsating) DC. Opposite, the unipolar-generators immediately produce DC of astonishing high strength at astonishing low voltage. The turning of the rotor demands power-input. However the demanded forces increase not proportional to the load - seemingly contradicting the common understanding of energy-constant. It makes problems to drain-off the current from these machines, e.g. because sliding-contacts produce heat and abrasion. Occasionally were use 'liquid contacts' (e.g. mercury or molten metal), thus techniques most complex.

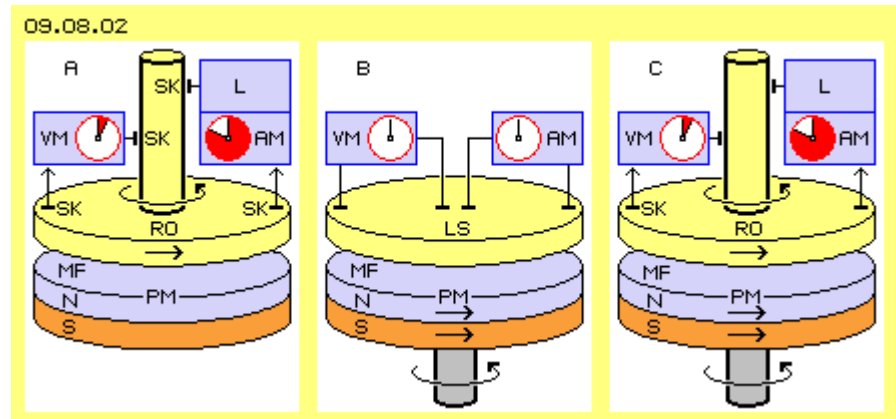

Rotating Magnets

That's why machines are preferred, where the conductor is stationary installed at the stator and the magnets of a rotor are turning around the system axis. So relative movements between conductor and magnetic field exists, resulting a current according to induction-laws. This variation is sketched at picture 09.08.01 at the middle at B. The permanent-magnet (PM) is mounted at a shaft. The magnetic field upside of the north-pole is left-turning. Also the shaft should turn left, so both movements add. The conductor-disk (LS, yellow) stands stationary within the rotating magnetic field. Via contacts again are connected a voltmeter and an ammeter - which show no deflections.

Also this result seems to contradict the rules of induction. At scientific discussions diverse explanations for the characteristics of magnetism came up, e.g. no field-lines could exist, the magnetic field could not rotate, mechanical effects could only come up by an electric flow etc. So this variation unfortunately was assumed not usable for generating electric current.

Based on my consideration however well could circulate eddy-currents at the conductor-disk. However these are running concentric around the axis and thus these sliding contacts can not pick up the flow. At the other hand the back-flow of magnetic field from north- to south-pole is not optimal organized. So probably a generated flow could be gathered at the stator - by suitable arranged constructional elements.

One-Part Faraday-Generator

As long as one does not know the causal connections, only the method 'try-and-error' may help (however I trust in 'think-and-error' and a score-rate some beyond 'fifty-fifty'). The researchers of century before last had great success with their 'wild' trying-out new things. Faraday for example did prove a third variation, which is sketched at this picture right side at C.

The permanent-magnet (PM) and the rotor (RO) as well are installed at a common shaft. Both are turning likely sense and likely fast within space, so no relative movement between both constructional elements exists. The magnetic field shows no changes during the rotation. Based on valid laws thus no induction should come up. If however previous voltmeter (VM) and ammeter (AM) are connected via sliding contacts, they show a (relative low) voltage and an (unexpected high) strong current, available for a load (L, blue).

Obviously this 'one-part Faraday-Generator' violates the induction-laws. At all common generators the turning element is affected by a resistance versus the stationary element and the back-affecting force of rotor is supported at the stator. Here however the magnet-disk is fix combined with the conduction-disk, so no mechanical part is given for suspected back-affecting force.

This generator demands draft. The demanded drive-force however is independent from the load taken off the system. So that Faraday-Generator seems also to violate the law of energy-constant. The public discussion thus mainly is searching for an approval of any kind of counteracting force. As this did not succeed satisfactory, the main-physics ignore consequently this problem since many years. However just because basic physical laws are involved, the explanation of these interactions could result new insight.

Without Voltage no Current

At previous picture 09.08.02 right side at C, the one-part Faraday-Generator is drawn only schematic. Without any doubt however such machines deliver DC at the rim, although practically no voltage exists between both sliding contacts. Some unipolar-machines produce usable current even of extreme strength. Common understanding can

not explain this appearance, because finally a tension U (lat. *ungere* = push, press, urge) can force movement of the charge-carriers (free electrons or ions) within an electric conductor. Without voltage (thus a work-potential between charges of different strength) no electric flow can come up.

What should cause free electrons (without according power impact) to move into a certain direction by vast amounts? How should a charge (existing only at the surface of the conductor) be able to affect force onto electrons (which are located inside of the conductor)? Above this, how should an electric and / or magnetic field be able to produce real effects through the Nothing of the alleged vacuum? These unipolar-machines approve clearly, the common understanding of electro-techniques are insufficient. Already Tesla and e.g. DePalma suspected other factors are involved, e.g. something like the aether (however nobody made up concrete definitions for this substance and the necessary functions).

Usual Construction

Picture 09.08.03 left side shows a longitudinal cross-sectional view of most used version of unipolar generators. The electric conductor-disk of the rotor (RO, yellow) is fix installed at a shaft. At each side a permanent-magnet is fixed, so the disk is covered by a north-pole (N, blue) and a south-pole (S, red). The magnetic field thus is turning like the disk. A voltmeter (VM, green) at the rim of the disk and at the shaft indicates only few voltage.

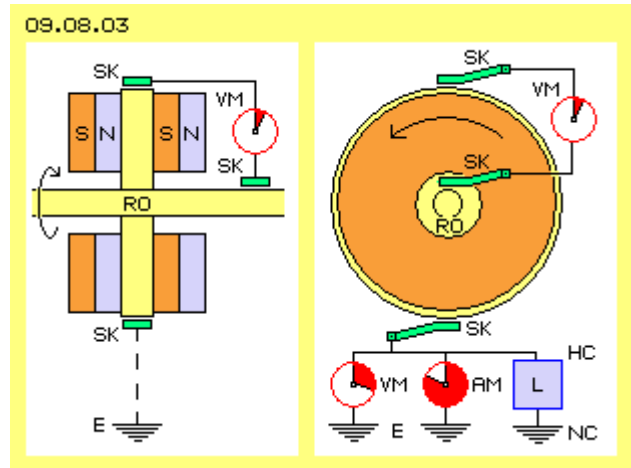

At this picture upside right that voltmeter is drawn once more. Now I suppose strong voltage exists indeed, however between the rim of disk and the earth (E). The atoms of permanent-magnet and of the disk are turning within the space. The magnetic flow contributes additional aether-movements. Thus an aura exists around the rotor (which might reach out several meter). These aether-movements have a stroke-component (like at every aether-whirlpool, see previous chapters).

This is equivalent to high charge (HC) and thus a potential exists towards the normal charge (NC) of the grounding. The Free Aether presses down the 'thick charge-layer' to the level of average charge. This is the usable flow, its strength is measured by an ammeter (AM) and it's available for a load (L, blue). The strong current of unipolar-generators e.g. is used for welding. At simple welding-method, the plus-pole-clamp is attached to the working-piece, thus practically grounded. The DC of the generator thus needs no back-flow-wire for closed conductor-circuit. Really necessary is only one wire from the disk-rim sliding-contact to the earth. This quite new understanding of processes will become clearer with following constructional variations.

Spoke-Conception

The basic principle can be build by diverse constructions. An example is shown at picture 09.08.04, upside at A by longitudinal cross-sectional view. The rotor (RO, grey) is build exclusive by iron (FE). A coil (SP, red) is wound within a deep groove, concentric around the axis. For excitation a DC is fed, resulting a torus-shaped magnetic field around the coil, marked by some dotted curves. So this rotor combines the function of magnet and of conductive disk same time. If that heavy rotor is accelerated to high revolutions, strong kinetic energy is stored (plus intensive aether-movements of internal magnetic flow). If the rotation abruptly is decelerated (in sense of an eddy-current-brake), current-impulses by millions ampere are generated (e.g. for ignition of 'rail-guns').

For 'civilian' applications that start-stop-mode is not usable. Demanded is a periodic change of motion-intensities. This picture at the middle at B shows a cross-sectional view of an according rotor (RO, grey). The coil (SP, red) is wound concentric around the axis. The magnetized iron (FE, dark-grey) however builds only some spokes (here e.g. eight). The sections between the spokes (NM, light-grey) can be empty or filled up by material non-magnetic and non-conductive. The magnetic field no longer is a closed torus. Within the groove now exist a magnetic fields of changing intensity.

Relative Movement

Induction comes up by 'pulsating' magnetic fields and / or relative motion between magnet and conductor. As mentioned upside, the cause of electric flow of the unipolar generators (or the question of perpetuum mobile) is discussed

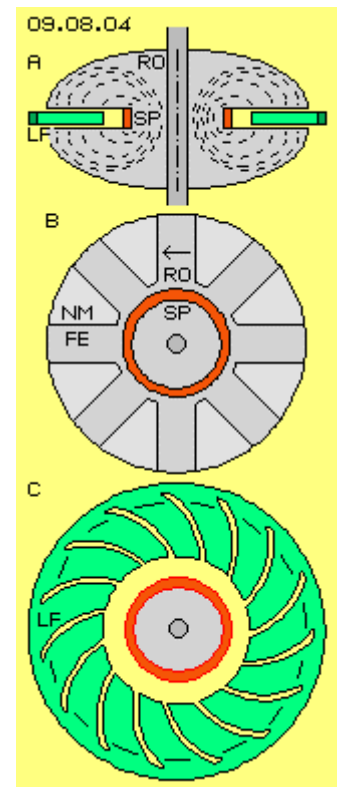

controversial. However one seems to agree in the fact, the stationary current-collector finally represents the demanded relative motion (or the support of suggested contrary force). If this constructional element has decisive importance, it should be build logical stringent.

The usual sliding contacts develop faults. The current collection via molten metals is not practicable. That's why here the charge-catcher (LF, green) are stationary constructional elements (of the stator) and reach far into the groove of the rotor (thus are replacing previous sliding contacts). Like sketched at longitudinal view at A, the charge-catcher (LS, green) do not touch the rotor. This picture below at C shows a cross-sectional view at the area of the charge-catcher.

Thrust of Aether

Already Tesla made the proposal for spiral sections of conductor-disk, in order to optimize the 'electronic flow'. Analogue, here the charge-catcher is divided into some spiral sections. Their curvature (from inside outward) shows into turning sense of system (here assumed left-turning all times). At the rim, the sections of the charge-catcher are connected, for guiding the (somehow pulsating) DC to the consumer.

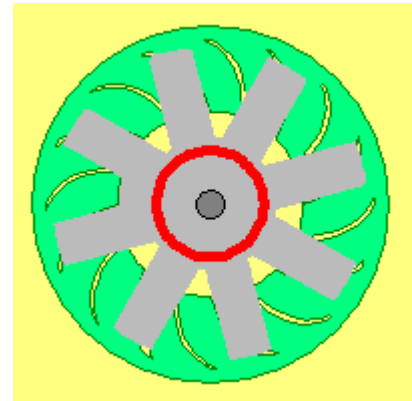

This animation clearly shows the relative motion. The spokes (grey) of the rotor move over the spiral faces of the charge-catcher (green), like 'windscreen wiper', however by opposite function. Each magnetic field 'smears' its motion-pattern onto the spiral bands. Thus a layer of intensive aether-movement 'sticks' at the surface. These are circling movements-with-stroke, deformed to garland-shaped loops. These motions demand a corresponding high aura above the surface. Finally the following gap (respective the non-magnetic fill-material) allows the Free Aether to flatten that 'charge'. The normal aether-pressure thus wipes-off the charge at these spiral tracks (where the garland-shaped stokes already show into wanted direction).

At the rim the charge is accumulated to high layers, building a potential gradient towards the normal charge of the ground. Finally there comes up the necessary 'tension', causing the electric flow, corresponding to the strength of the current. No 'charge-carriers' are running through the conductors (only as a second appearance some free electrons are crawling through the wires). No aether is floating through the space. All aether all times keeps its place at the charge-catchers and along all conductors. The rotating masses of rotor and its magnetic fields just pile up some 'aether-turbulences' at the surface of the charge-catcher, which at the following are lowered and pushed aside by the normal pressure of Free Aether.

Above the charge-catcher remains the same 'aether-volume' all time. The aether there is whirled-up by the rotor-spoke and magnet-field. At the following gap, the Free Aether eliminates that 'disturbance'. That motion-hill is shifted to regions with thinner charge-layers, thus towards the ground. Because there are no 'charge-carriers' in shape of electrons, none of must be fed-back. All aether along the charge-catcher and the conductors is only whirled-up some higher and afterward is smoothed-down. At the charge-catchers periodical a 'wave is piled up', slosed along the conductor and running-off into the ground.

Many Variations

At picture 09.08.06 upside left at A the rotor (RO, grey) is sketched by longitudinal cross-sectional view. That rotor mainly exists by non-magnetic material (NM, light-grey). Embedded are some electro-magnets (EM, dark-grey and red), building a concentrated magnetic field between their north-pole (N, blue) and south-pole (S, red). Upside right the picture shows a corresponding cross-sectional view.

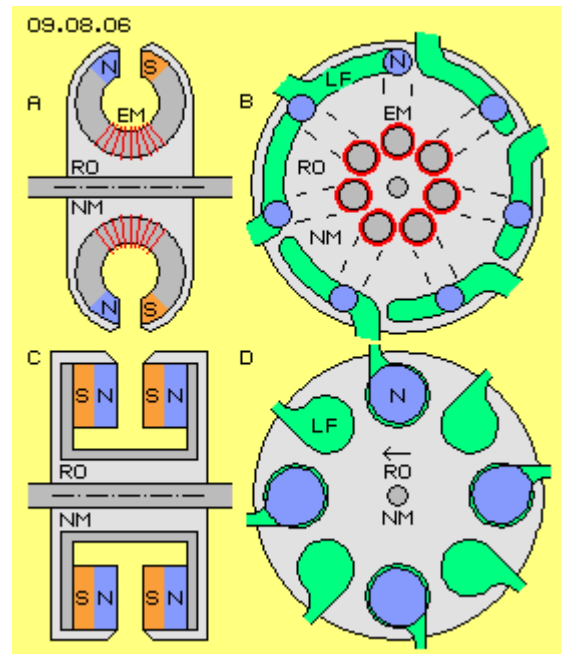

As an example, seven of these magnets are drawn. During the rotor-revolution, they are moving over six charge-catchers (LF, green). Each magnetic field is 'painting' turbulent aether-movements at the arch-shaped charge-catchers. Afterward at next gap, the Free Aether flattens that high reaching motion-layer and finally presses-off that charge from the area of the rotor. Naturally diverse magnets and charge-catchers can be installed as one likes it, also several modules aside each other at the shaft. That generator will produce relative steady DC or pulsating DC e.g. by two or three phases.

Simple Model

At this picture below at D for example eight charge-catchers (LF, green) are installed at the stator and four magnets at the rotor (RO, light-grey). Here schematic are marked the north-poles (N, blue), moving over the faces of the charge-catches as the rotor is turning around. This arrangement produces DC by two phases or steady pulsating DC. For a simple functional model some round permanent-magnets will do. In order to achieve closed magnetic flows, each two magnets could be connected by a yoke (dark-grey), like sketched at this picture below left side at C by longitudinal view.

Generator plus Motor

Unfortunately it's still an open question, whether N-machines respective unipolar-machines represent a perpetuum mobile or not. As everyone knows it's not quite simple to measure the energy-input and -output of a system, because each measurement by itself affects the running process. That problem is indisputably solved only if a machine can produce its own drive - and probably produces some energy-surplus. At picture 09.08.07 a proposal for simple construction is sketched.

At a common shaft (dark-grey) a generator and a motor are fix installed. Left side at this shaft, previous generator with its simple permanent-magnets is drawn. The charge-catchers (LF, green) are connected by a wire, guiding the current from that high charge (HC, see arrows) to the motor at right side.

Suitable for drive could be a Faraday-Motor, just because it's the reversal of that principle and as it demands only simple constructional elements. The stator (below right) is represented by two permanent-magnets, which are connected with a yoke (dark-grey). The rotor is a disk (LS, green) built by electric conductive material (e.g. a copper-disk, fix mounted at the shaft). A sliding contact (SK) feeds the current inside and a second contact takes it off at the rim. The conductive disk practically represent many radial wires. When current is running from inside outward and through the magnetic field (see arrow), the Lorentz-force is affecting onto each 'wire', resulting a turning momentum and thus driving that motor-disk and also the rotor of the generator.

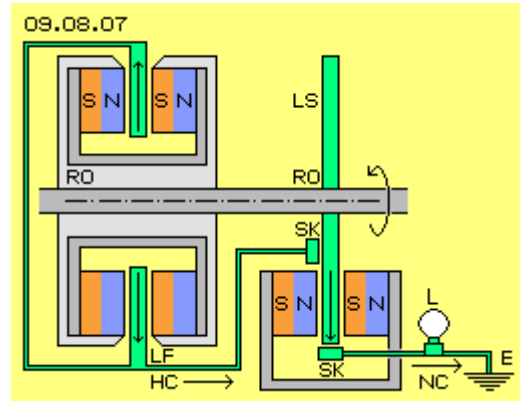

Overunity

The Free Aether drives the high charge (HC) of the charge-catchers through the whole circuit along the conductor-surfaces, into the sink of normal charge (NC) of the earth. The motor must drive the generator and must overcome the friction within bearings and at the sliding contacts. If finally also a small lamp (L) would shine, the prove for a self-running machine and efficiency beyond 100 percent would be perfect.

Professional physicist worry about energy-constant - even no danger exists at all. However that law is valid only within the gapless aether, because only its movements never can got lost (opposite to the 'world of material particles'). Like at fluid-technology, energy exists unlimited, there e.g. in shape of the normal molecular movements. Here infinitive energy exists by the steady narrow 'trembling' of Free Aether and its pressure versus all wider movements. At least via permanent-magnets the motion-pattern of magnetic fields are available 'for free'. It is 'only' necessary to organize given movements temporary that kind, a wanted benefit is achieved.

Here a local turbulence is generated by the turning of the rotor combined with the spiral-turning magnetic field-lines. The aura of that 'disturbance' reaches high above the surface of the charge-catcher. The Free Aether affects pressure, pushing the movements down to likely level - and thus drives that movement-hill - named electric current - into the charge-sink of the earth. No change occurs concerning all movements as a whole (equal to 'energy'). At fluid-technology the skillful organization of flows produce 'overunity' without any doubts, e.g. at each wing (the curved faces generate relative emptiness and accelerated flow, the difference to normal air pressure represents the lift-force). Analogue here such local and temporary 'disturbances' are generated, which are transferred into flowing charge respective electric current - by just normal aether-pressure.

The consequent realization of previous proposals could finally approve, if the strange effects of unipolar-machines result the performance of an overunity generator. Common generators produce voltage and flow in changing directions. All aether-movements thus must be delayed and accelerated again into opposite direction. So work-load exists on and on versus the inertia of aether-movements. At previous conception of unipolar-machines all aether-movements are running into same turning sense all times. At the faces of charge-catchers exist only higher and lower vortices, periodical changing, practically only an upward-slosh and falling-back vertical to the surface. The Free Aether is working (for free) like a pump as the high vortices become reduced to normal size and pushed along the conductor. That working-principle well could be economic (i.e. show more benefits than costs).

09.09. Railgun- an Ballbearing-Effects

Ultrasound-Missile

At previous chapter was mentioned, unipolar-machines are driven also as an 'eddy-current-brake' to generate extreme strong current impulses. For example, these are used for 'rail-guns' to accelerate missiles up to ultrasound speed. The general principle is sketched at picture 09.09.01. The projectile (P, green) is build by electric conducting material and rolls or glides at two parallel rails (R, black). A current (many amperes strong) is fed into one rail. The current flows along the projectile and back again via the second rail, as marked by red arrows from minus to plus. The projectile is accelerated extremely into direction of the green arrow.

The common explanation here is also sketched. Around the rails comes up a strong magnetic field, each left-turning in direction of the current, as marked by the blue circle-arrows. The projectile practically is a conductor for the current, crossing the magnetic fieldlines right-angles. So the projectile is affected by Lorentz-force, again by right-angles. Right side below the common hand-rule is drawn (here based on physical direction of current, thus left/right-changed). The magnetic field (B, blue) shows down, the current (I, red) flows through the projectile towards left-upside, the resulting force (F, green) shows upward-right.

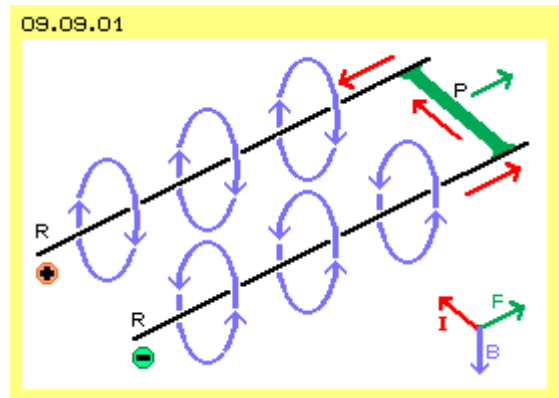

One well knows, this explanation is not really sufficient. For example, also around the projectile comes up a magnetic field, again left-turning, thus showing downward at its backside (left). Within a fluid, three parallel flows would produce 'suction' - and analogue one can imaging the 'flowing' of magnetic fieldlines. Thus the projectile would be pulled towards the source of the current and would not be pushed off. However these guns practically function - even no clear knowledge about the theoretic functions exists.

Ball-Bearing Motor

As this linear acceleration functions, also accelerated rotation should be possible. Diverse explorers thus experimented with 'ball-bearing-machines'. The general principle is shown at picture 09.09.02 upside left at A by cross-sectional view and upside right at B by longitudinal view. Previous rails practically are bended to rings. The outside ring (RA) is fed by voltage. Via glide-contact at the inner ring (RI) respective at the shaft (dark grey) the current flows back to the source. Between both rings some balls (K, dark grey) are running around, building the electric connection. Also this motor functions, even its construction is merely mentioned at textbooks. Obviously one welcomes, that "the efficiency is rather small" and thus there is no demand for explaining the working effects. Opposite, some researchers achieved most surprising results.

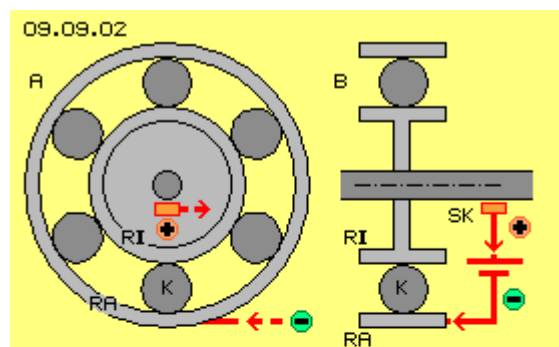

Walter Thurner e.g. build an unipolar-machine, where the electric contact between stator and rotor was realized by balls running around. In general, this corresponds to previous conception, however added by the magnets of an unipolar-machine at the central area. The machine did work as a generator with good efficiency. However the drawing-off the current via rolling balls made some problems, e.g. as heat comes up. Opposite, if current is fed into the system, the machine did work as a motor, accelerating up to 10000 rpm - until self-destruction. Obviously come up great vortices within surrounding aether, resulting that self-acceleration and merely to control.

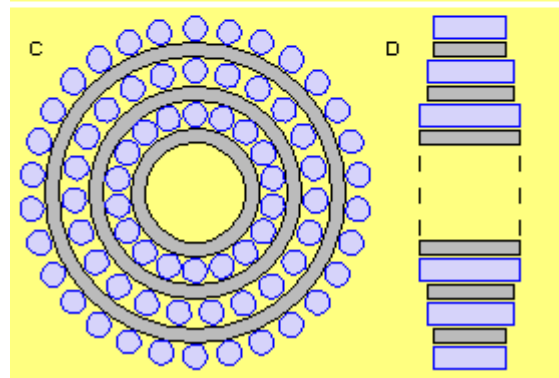

Magnet-Machines

Strong swirls within the aether are also achieved, when permanent magnets rotate. Well known e.g. are manifold experiments of John Searl. The general conception is sketched at picture 09.09.02 below, left at C schematic by cross-sectional view and right at D by longitudinal cross-sectional view. In principle were used several rings (light grey) which can be stationary or turning. Between or around the rings, some cylindrical 'runners' (blue) are installed, which are turning around the system axis and their own axis same time (practically rolling along the rings). All constructional elements are build as permanent magnets, partly by multiple layers with complex structure and polarization into differing directions.

The reports about appearing effects are contradictory. However it might be true, 'levitation' was coming up and some of Searl's discs did fly off. Probably some later, Searl was able to control the acceleration. At any case came up electric voltages and flows. Many speculations exist about analogue appearances at UFOs. Probably Searl was able to build reliable working current-generators. As a whole however, the stories about John Searl are so confusing, they can not be used as a basis for analysing the decisive effects.

Better documented are the experiments of Wladimir Roschtschin and Sergej Godin. They build stationary rotor-systems, somehow analogue to Searl respective corresponding to these sketches in general. They measured weight-losses up to 35 percent. At the bottom, the generated aether-vortices are affected by stronger resistance than at the top. The 'stress' at the bottom lifts the whole system upward. The aether-vortices showed effects also within neighboured rooms and upside floors. Without any doubts, self-acceleration did come up, so Roschtschin/Godin did take care to limit the revolutions of the system to only 600 rpm.

That 'magnetic energy converter' (MEG) had a diameter of about 1 m and achieved a performance of 7 kW. Unfortunately that unit for usage of 'free energy' still is not available. Probably also here the magnets are build too complex. In general, long term rotating permanent magnets become fragile. Based on these problems, also these well documented experiments can not show the true cause of generated effects.

Simple Runway

Based on these and other experiments one can state one fact without doubts: there are not only pure mechanic motions, there are not only interactions between magnetic and electric fields, but the decisive effects can only occur within the real substance of surrounding aether. One must go back to the most simple arrangements for analysing the process. Therefore two known experiments schematic are drawn at picture 09.09.03. A view top-down is shown at A, a cross-sectional-view at B and a side-view at C. At two rails (light grey) rests a round cylinder, build by two permanent magnets. It's told the experiment will function only if both south-poles (S, red) meet at the middle and the north-poles (N, blue) are showing outward. If a DC is fed into one rail, the currents flows along the iron-cylinder and via the second rail back to the source.

Especially by the cross-sectional view at B it's apparent, there is no clear way for the back-flow from north- to south-pole. The magnetic fieldlines e.g. leave the left north-pole and can take the upside way to the left south-pole, however can enter only from aside. Symmetric can run the back-flow of the magnet right side. Both magnetic fieldlines however meet contrary turning at their south-poles. Above this, the magnetic back-flow is hindered aside and below by the rails and their magnetic fields. When that cylinder is rolling along the rails (and it does indeed), even more complicated aether-vortices come up. So also this arrangement gives no clear picture for the decisive aether-movements.

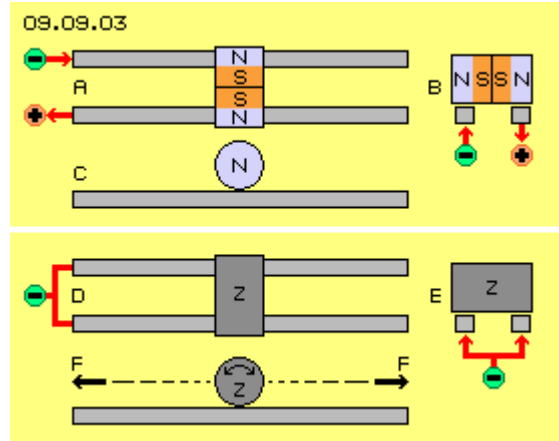

Rolling both Directions

Below at this picture 09.09.03 now the most simple arrangement is drawn, at D by view top-down, at E by cross-sectional view and at F by side-view. Voltage is put on both rails (and few volts will do). A round iron- (or steel-) cylinder (Z, dark grey) lays on both rails, building an electric connection. The whole system is connected only with the minus-pole of a (DC-) electric source. There is no connection to a plus-pole or to the ground. So no flow is running, but the rails and the cylinder are only 'static charged'. If now the cylinder is started to roll, it goes on rolling and accelerates by itself. One can start the cylinder to turn left or also towards right side - into both directions it will roll further on and accelerate automatic (see both arrows F). At the internet one can read meagre statements like this: "a static charged cylinder shows a turning momentum into direction of its movement" - an explanation 'why' one will merely find - because impossible by conventional understanding.

This experiment is most simple and the result is just 'incredible'. At a congress or workshop I witnessed that experiment and tested it by myself. I clearly remember the astonishing result, even I was not involved in electromagnetic appearances of the aether at that time. So unfortunately I do not know, where and when and who demonstrated the experiment. At the other hand, everybody can repeat it respective it should be basic-equipment at every school. All students must learn the rules and laws of electromagnetism, which are proven by experiments and the effects are explained at its best. It's also pointed out, these explanations are only 'mental models for easier understanding'. And just here this experiment would fit - because obviously showing, the ideas of common physical understanding are totally over-strained respective are excluding the most decisive aspects.

Charge-Shell all-around

At picture 09.09.04 upside, this experiment is shown once more, again by view top-down (A), cross-sectional view (B) and side-view (C). As no current is running, one rail (S, light grey) will do. The round (iron-) cylinder (Z, dark

grey) might be suitable at its best with an oval cross-section at its long axis. Voltage is put onto the conductive rail, so all around its surface exists electric charge. That static charge will also cover the electric conductive cylinder.

Previous chapters already did show how far the static charge can reach into the space, e.g. when rubbing a PVC-ruler with a wool-sheet. So relative small voltage will be sufficient to cover the device completely with a 'charge-shell'. The aura of static charge here is marked light-green. The swinging-pattern of static charge was described at previous chapters e.g. at picture 09.05.02. Generally, starting from the surface, manifold wounded connecting-lines are directed into the neighbouring space, swinging synchronously, the further outward by each smaller size. The Free Aether presses that motion-pattern towards the surfaces, so that motion-layer shows likely height all around. Upside of the cylinder thus a 'charge-hill' comes up and also aside of the cylinder these aether-movements reach some further out into the space.

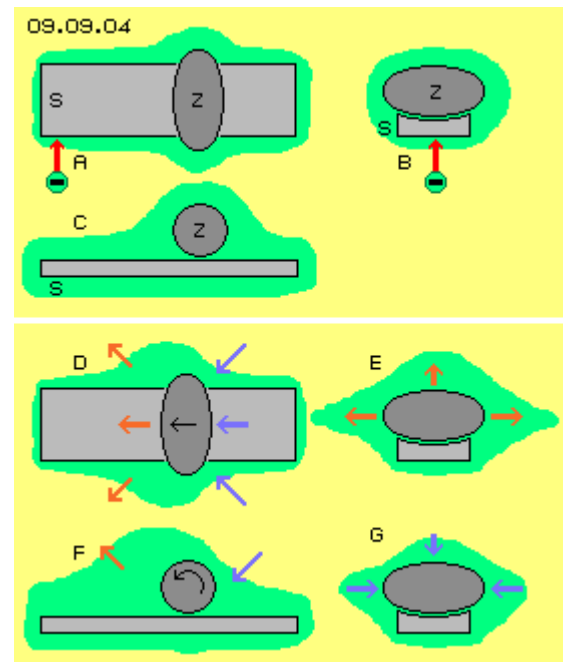

Aether is shifting Mountains

At D, the cylinder was pushed softly, so it starts to roll to left side. This mechanic motion affects additional aether-movements, so the aura around the cylinder is some enlarged. At the cross-sectional view at E, the green marked areas show that expansion upside and at both sides. The red arrows show the direction of that widening.

Even these constructional elements are conductive, the charge 'keeps static' at the surfaces (see also below). As the cylinder is turning, also its charge comes into a turning respective forward-directed motion. The 'charge-hill' of the cylinder is pushed upside over the charge-layer of the rail. At the side-view, the red arrows F show, how the green area of charge-movements is piled up in front of the cylinder.

The ordered and wide-swinging motion-patter of the charge becomes wider by the rolling cylinder and the border-surface of that aura also becomes larger against the Free Aether. Some time later thus increases also the effective face for the general aether-pressure. As soon as a 'weak-spot' comes up, the charge-layer will be pressed nearer to the surface again. At the rear side of the rolling cylinder, its charge is drawn off the (here rather flat) charge-layer upside of the rail. Into that area of relative weak aether-movements, now the Free Aether can affect pressure, like marked by the blue arrows. So in front of the cylinder occurs an expansion of the motion-aura (see red arrows at F). At the back end, the cylinder is rolling off and the volume of involved aether is reduced (see blue arrows at G). At the front, the spiral swinging of the cylinder-charge and the rail-charge are crossing, i.e. both as a whole will reach out rather far. At the rear end, both motions become separated, so there the swinging layer becomes weaker.

Current follows Voltage

An electric generator (the usual units or of previous chapters) pile-up strong charge onto a conductive surface (building a potential respective 'tension' versus areas of less charge). Finally by a second step the flow of electric current comes up (because the general aether-pressure pushes the charge-layers down to likely height at all surfaces). So generally is valid the rule: 'the electric current chronological follows the voltage'. For example, at 50-Hz-AC the current follows with a delay of 90 degree of the phase, thus about 0.005 s later.

At chapter '09.05. Current' e.g. at picture 09.05.04 was shown, how the general aether-pressure pushes the charge-hill of DC along a conductor - nearby with speed of light and minimum loss. Here at this experiment, the electric source installs a uniform charge-layer at the surfaces. However above and aside of the cylinder the layer is enlarged, thus building an 'artificial' charge-hill. When the cylinder is resting, that layer hangs symmetric around that hill. If the cylinder gets rolling, an asymmetry comes up and the Free Aether pushes that charge-hill forward, inclusive the embedded material cylinder - just like the charge-hill from the DC-generator. When current is moving along a round conductor, the enlarged charge builds a ring-shaped expansion. Here the cylinder can build a hill only at one side above the rail. Here the cylinder is drawn with an oval cross-section which might show best effects, as the charge at the front side is 'squeezed' upside-out and at the rear end the aether-pressure can affect concentrated into that deepening.

With concern to the speeds, however grave differences exist. At AC at first occurs the extension of the charge (producing the voltage) and already 0.005 s later starts the compression of that hill. Here the cylinder must roll forward one diameter until the outward pressed motion of the front side can be compressed again behind the cylinder. If the cylinders has a diameter e.g. of 5 cm, it must move forward e.g. by 10 m/s to achieve previous frequency of AC. As long as the cylinder is rolling slow, the potential of the aether can affect only by parts.

Nevertheless the cylinder becomes accelerated, however the aether can drive much higher frequencies. The faster the cylinder rolls, the higher the hill at the front-side is piled-up and thus the stronger works the following aether-pressure, pushing the cylinder forward. At optimum conditions thus the cylinder will not accelerate linear but progressive. This is told how railguns do and thus should be possible also at rotating systems.

Excursus: Relation of Speeds

The electromagnetic waves are racing through the space by speed of light, from and into all directions, thus crossing everywhere any time. The movements of Free Aether are a mixture of these overlays. It's 'trembling' respective it's running at 'chaotic tracks' within narrow space, nevertheless all times by speed of light with some 300000 km/s. A 'material body' can move only slow through that 'stationary' aether, as the complex vortices of the atoms are forwarded into drive-direction. Still e.g. the earth wanders with about 40 km/s around the sun and whole sun-system travels around the galactic centre up to 260 km/s. So the earth is moving by remarkable 300 km/s through the space - nevertheless 1000 times slower than the internal aether movements.

The sound-barrier often is the limit for our technical applications, e.g. as airplanes travel little bit slower than 300 m/s. If a rotor has a diameter of 1 m, that speed at the rim is achieved by 18000 rpm. So 'technical usable' are only speeds, which are 1000 times slower than the cruising speed of the earth. So if a mechanic constructional element is moving thus fast, its atoms wander through the aether 1000000 times slower than the aether internal is moving anyhow. If the 'chaotic curved tracks' of the aether would be straight lined up and e.g. 1 km would be done each time-unit - that mechanical part would move forward just 1 mm during that time-unit.

The earth is drifting passive within the aether, driven forward by that minimum 'stroke' of its whirlpool. The fastest possible movements of mechanic constructional elements show even smaller differences within the normal motion of Free Aether. When here at the pictures a 'stroke-component' is marked by thick arrow, the aether really is moving only a millionth part different to its average behaviour. Nevertheless these motion-pattern of minimum divergences have 'striking effects' - however only because the aether is gapless, thus neighbouring aetherpoints must behave adequate and every local divergence inevitably must be balanced within the environment.

Ball-Bearing

At the following are discussed the effects, which can come up at rotating systems. At picture 09.09.05 upside left at A the cross-sectional view shows an outside- and an inside-ring (RA and RI, light-grey) and some balls (K, dark-grey) between. The outside-ring is stationary, the balls are right-turning around their own axis. They are rolling left-turning around the system-axis and thus are shifting the inside-ring by double revolutions around the system axis (see arrows), like it's normal function of a ball-bearing. Upside at the middle at B is sketched a corresponding longitudinal cross-sectional view.

Like at previous railgun-effect, that system will be charged. The piling-up of charge above the rolling balls here however is hindered by the inside-ring. If more than these four balls are installed, also the space between the balls is rather narrow. So if self-acceleration comes up at a ball-bearing-system, other effects must be working. These won't occur between the balls, but could function aside of the balls. At this case, flat discs might be suitable. That's why 'wheels' (R, dark-grey) are drawn between the outside- and inside-ring here at the longitudinal view upside right at C.

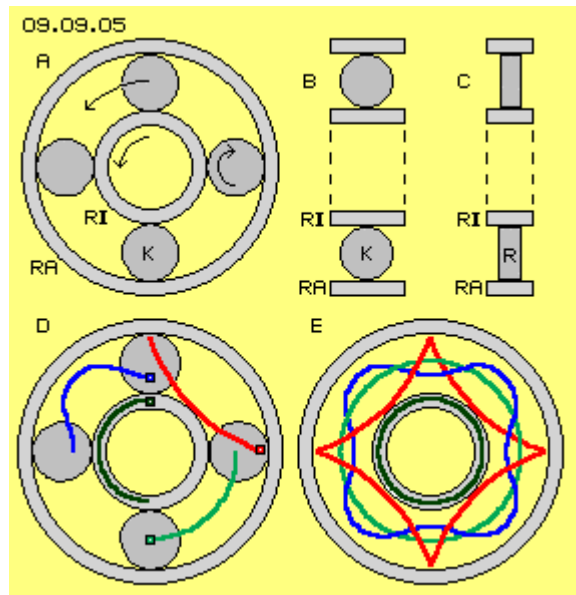

Confused Tracks

A ballbearing is a 'round stuff'. However on closer inspection, there are not only pure circling motions. Below left at D some mass-points are marked at the wheels and their tracks are shown by curves. One point at the centre of the wheel below is marked light-green and that point is really moving at a circled track (light-green) around the system axis. A point at the rim of the wheel at left side is marked red and that point is 'jumping': at first it becomes faster running inward-forward, some later it's guided outward and slowed down, finally nearby standing still for a short moment. All mass-points at the rim of a wheel 'bounce' around the system axis at that curve marked red (like e.g. all mass-points of a tire are jumping forward by such bows over a plane street).

At the wheel upside a point between the centre and the rim is marked dark-blue. Such mass-points sway or stagger at S-shaped tracks (dark-blue) around the system axis. Only the mass-points at the inside-ring, here marked dark-green, again are turning at circled track by constant speed around the system axis. They rotate by double revolutions, compared with the speed of mass-points at centre of the wheels: the dark-green track is 180 degree long, while the light-green track is only 90 degree long. At this picture below right at E, these movements

are drawn during one complete revolution. These are the tracks of only four mass-points. The diameter of the wheels is exactly one quart of the diameter of the outside-ring. Naturally could be installed more wheels and the diameters must not show integer relation. Each mass-point at each wheel is running at its own track. Instead of a 'round stuff' such ball-bearings show a confusing follow of motions.

Clear Pattern

Nevertheless exists a common and clear motion-pattern, which is shown at picture 09.09.06 at A by side-view. Between the outside- and inside-ring (RA and RI, light-grey) is rolling a wheel (R, dark-grey) towards right side. At this wheel are marked many points and red lines indicate the direction they are moving momentary. In addition, the lengths of the lines indicate the momentary speed. All points of left side are moving upward, some later into horizontal direction and finally right side down. Below, the inclination is strong and upside, the inclination becomes flat. The speed of point upside is generally faster than the speed of points below. All points momentary are moving as if they would swing at a bow around the suspension-point (marked as fulcrum DP) of the wheel at the outside-ring.

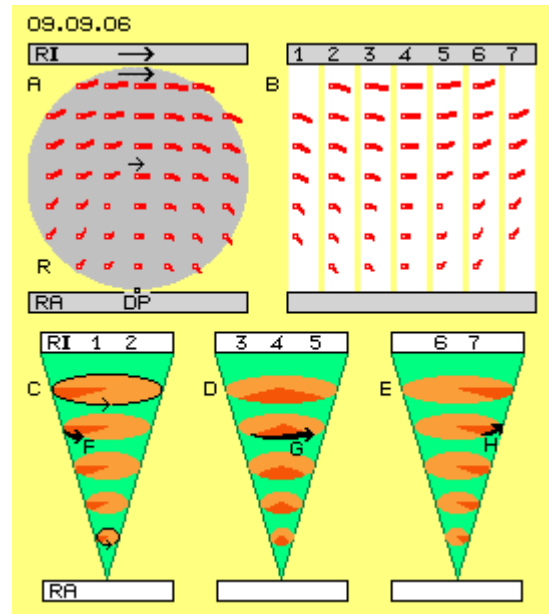

This view from outside shows the movements of the wheel as a whole. At B the white column 1 represents a 'window', through which one can see only a part of the rolling wheel behind. At first moment in time, only the points of the right wheel-border is visible with their downward directed motions. At following moment 2 in time (next column right side), some more points and lines are visible at the window. At moment 3 in time, the motions become more flat. At moment number 4, all observed points are moving horizontal towards right side, upside much faster than below. At the following moments 5 and 6, the movements show upward more and more. At final moment 7, the left border of the wheel leaves the window. The movements of both halves of the wheel thus are symmetrical. The motion-pattern visible through that window however is opposite to previous total side-view at A.

That 'window' thus shows by view of a 'resting observer', how each atom of the wheel is moving at each time-section. Just like this, the wheel appears for the 'stationary' Free Aether aside. Only the motion-pattern of atoms wander at these tracks through the aether. Only temporary these areas take the complex motion-pattern of atoms. When the atom has passed-by, the aether comes back to its normal motion. So the wandering of the atoms directly affects only the aether within the area of that ball-bearing. The Free Aether aside is only previous 'indifferent onlooker'.

Resonant co-swinging Free Aether

When atoms are moving continuously at likely tracks, the aether will not come back to its original movement completely. The atoms leave a 'trace', here in shape of that 'bow-shaped stroke'. As all aether is coherent, also the neighbouring Free Aether becomes 'resonant' swinging, at least when a clear motion-pattern exists. At this picture below at C is sketched a typical cone, representing the motion of a connecting line. At level of the stationary ring (RA) the aether 'trembles' at narrow space. Towards the inside-ring (RI) the mechanic motions are faster and at corresponding wider tracks also the aether will swing. This cone is drawn once more at D and at E.

The atoms are driven all times by a stroke-component respective opposite, here the mechanical motion is replicated by motions with stroke-component within the neighbouring aether. These strokes here are marked by dark-red sections and the remaining part of circling motion is marked light-red. At previous moments 1 and 2, the strokes show down, like marked by arrow F. At following moments 3, 4 and 5, the strokes show more horizontal, like marked by arrow G. At the moments 6 and 7, the strokes will turn upward again, like marked by arrow H. At the remaining time (and between the wheels) the aether can come back to normal swinging movements.

Resonant co-swinging Charge

Like mentioned upside with the relations of speeds, that co-swinging represents only millionth parts of the average movement of Free Aether. Nevertheless this represents an additional motion, demanding corresponding wider area for balancing movements. At picture 09.09.07 at A thus left and right side of that wheel (R, dark-grey) is marked a light-red 'aura'. This will be small near the stationary outside-ring (RA, light-grey) and will reach further out near the fast turning inside-ring (RI, light-grey). As a whole however the normal trembling of Free Aether is changed only little bit.

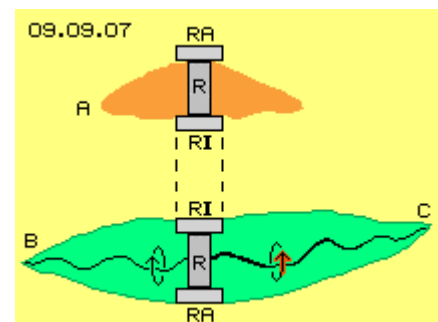

The whole system could be charged. The ordered swinging-pattern of charge reaches much wider into the space, like marked by light-green area at this picture below left at B. All aether there is synchronous swinging, here indicated by the spiral black connecting line. That charge-pattern naturally can take also the additional swinging of the rolling wheel. Within these clear ordered movements, the additional pattern will be represented just as clear. The aura of the combined swinging movements with its additional stroke-component will reach out even wider into the neighbouring space, like marked by the green aura at right side below at C.

Upside was mentioned, the charge would 'stick' at the surface. This is valid only by parts. Only magnetic fieldlines must exist into space, exactly from their spot of source at a north-pole. Opposite, also the 'static' charge can be shifted along the surface of a conductor. As here however that charge takes the motion-pattern of a rolling wheel, the charge executes the additional movements, just as if it would really turn synchronous with the material wheel. By that sense, the charge really 'sticks' at the forward rolling wheel. However, again only that motion-pattern of the charge (inclusive the stroke-components) are forwarded within the stationary aether. So at that charged system, a much wider aether-volume is involved, reaching much further outside than the volume of the material constructional elements of that ball-bearing.

Excursus: asymmetric Whirlpools

Wide-range movements within the gapless aether can only come up by extension of narrow tracks. The radius of swinging motions become longer and the track of the connecting-lines build a cone. As a rule, the swinging is unequal based on overlaying motions, which inevitably result stroke-components. These strokes e.g. drive the vortex-complexes of 'material particles' forward within the aether-space. Every motion must be balanced within a local area same time. For example, the swinging of an electron all around is 'time-shifted', e.g. like discussed by the 'clocks' at picture 09.03.03 of previous chapter.

That asymmetry is indispensable at whirlpools of every size, e.g. also at sun-system. The sun inclusive its aether-vortex drifts within the galactic vortex. That's why the earth moves not at an exact circle and with differing speed around the sun. By opposite view, the sun is moving at known Analemma-curve, like sundials show. When the moon is positioned between the sun and the earth, it stays some back behind the earth and overtakes the earth at the following days - because the whirlpools of the sun and of the earth are overlaying. Every day the geostationary satellites are running some ahead and stay back the following night. Details see at chapter 08.17. 'Aether-Vortex of the Earth' of the book 'Something Moving'.

Potential- and rigid Vortices

Also the aether-movements of that mechanic ball-bearing can only result by extension of swing-radius (in shape of cone-tracks of connecting-lines) and overlaying motions (here especially of the charge-pattern). In addition, the movements of the atoms result a stroke-component within neighbouring aether (or opposite, they drift within these aether-movements or they are pushed forward by these strokes). And all involved aether-volumes must move adequate all around, so finally all motions mutually compensate each other.

At picture 09.09.08 upside that ball-bearing is drawn once more, at A and C by longitudinal views. Inside of the inside-ring (RI) a shaft (W, dark-grey) is drawn (corresponding to normal function of a ball-bearing). From the outside-ring (RA) via the balls (K) to the inside-ring (RI), the turning-speeds are increasing (like generally at potential vortices). Opposite the atoms of the shaft are moving slower from outside inward (like at every rigid vortex). At this picture upside at the middle at B, the extension of the motion-intensity is marked by green cones. Towards the centre, the motions become slower, like marked by the blue cones.

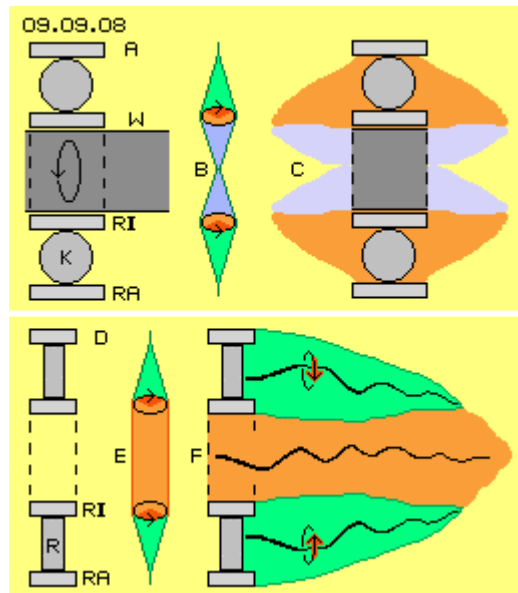

These motions must be balanced towards the Free Aether. That aura aside of the ball-bearing is schematic drawn upside right at C. From the stationary outside-ring further inward, the balancing-area reaches further out into the space (marked red). From the inside-ring inward, less balancing-area is necessary (marked blue). This is the common vortex-pattern of all whirlpools, e.g. also of the earth: from the border of the earthly aether-vortex (radius about one million kilometer) further inward, the stroke component becomes stronger, e.g. pushing the moon forward by about 1 km/s. At height of geostationary satellites the drift is about 3 km/s fast. The 'rigid' earth decelerates the vortex, so from earth-surface inward the absolute turning speed is linear reduced.

Central-Vortex of Ballbearing

If at the centre of the ball-bearing exists no massive rigid body, an other vortex-structure will come up. At the picture below at D an extreme case is sketched, where the area inside of the inside-ring (RI) is completely empty.

So no necessity for reduction of motion-intensity exists at the aether there. At E is marked by the red area, that the extension and stroke-component of aether-movements can reach unchanged through that central area.

At the longitudinal cross-sectional view at F, the green faces mark the area of charge, here represented by manifold wounded black connecting-lines (here is drawn only the right side, left side would be analogue). The charge-layer aside reaches far out into the space. These movements will not end exact at the inner border of the inside-ring. That clear motion-pattern can spread unhindered into the central area, like marked by the red area. There the aether moves corresponding to the aether of an electrostatic charge. As an additional overlay there exists also the motion-pattern of that 'bow-shaped stroke' which resulted from the mechanic motions of the ball-bearing.

Oversize Speed

At picture 09.09.09 upside left at A, a cross-sectional view of the ball-bearing is drawn. Between outside- and inside-ring (RA and RI) are arranged eight wheels (R). Below at this cross-sectional view the increasing motion-intensity from outside inward is marked by the green cone. The lengths of the red lines indicate the speed respective strength of the stroke-component. All rolling wheels all around result that 'bow-shaped stroke' within the neighbouring aether aside. The sectors of strokes are drawn at the inside-ring all around. That motion of aether corresponds to the high revolution speed of the inside-ring.

Within the central area, the aether can behave likely. The sectors of strokes come closer to each other and finally, within the narrow space of the centre, they build a closed circle (see red bow-shaped curves and central red ring). At the picture upside at the middle at B, the extension of motions are sketched by round faces. The outside-ring is stationary and the small red face represents only the narrow 'trembling' of Free Aether. Further inward, the aether-movements become wider and a sector of fast motion comes up (the stroke-component, dark-red) plus a sector of slower movement (for balancing, light-red). At the inside-ring, the sector of stroke is most wide.

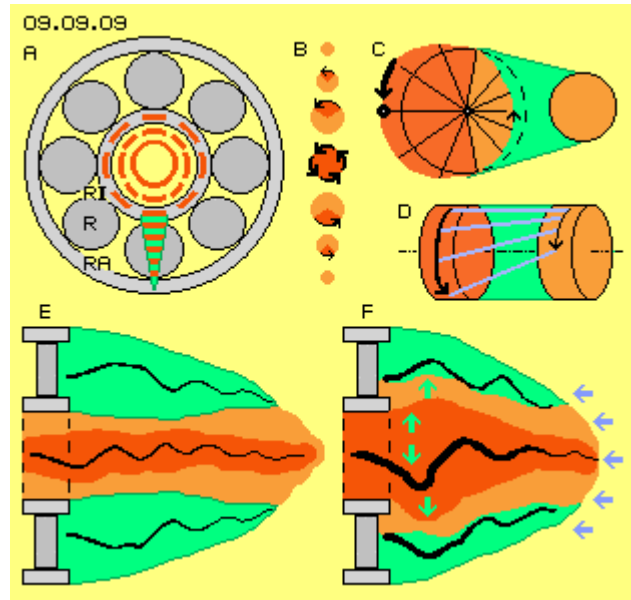

Acceleration by Aether-Pressure

As now that motion-pattern is not hindered to spread into the central area, the fast motions of strokes follow directly one by next, here marked by the dark-red face and four black arrows. The aether at the centre is 'turning' faster, because it's motion exists only by stroke-components. At this picture below left at the longitudinal view at E, that central area of 'oversize' aether-motions is marked by dark-red face. Like this, the aether inside of the inside-ring behaves. Aside of, the charge (light-green) reaches far out into the space. Within that clear motion-pattern these additional stroke-components (light red) unhindered can spread further inward. At the centre the swinging of the charge is complemented by the intensive strokes (dark red) to an 'oversize' frequency.

The more intensive that 'increased charge-swinging' becomes, the further outward reaches the aura aside into axial direction. The surface of the aura increases, so the Free Aether can affect stronger counter-pressure, like below right side at F is marked by the horizontal blue arrows. The general aether-pressure can compress these movements into longitudinal direction, however can not stop these intensive motions. That motion-pattern become only corresponding wider, like marked by the vertical light arrows. So that central motion-pattern is shifted into areas of inside-ring and the wheels. That pattern of compressed strokes represents high revolution-speed. In comparison, the 'material particles' are turning too slow. The inside-ring and the wheels are affected by additional thrust, i.e. they become accelerated until they correspond with that stronger drift-speed. The revolutions of the ball-bearing are accelerated, thus demanding extended aura aside. The faster turning inside-ring results stronger stroke-sectors. These spread into the centre and produce stronger pressure into axial direction. The counter-pressure of Free Aether again results a new phase of previous acceleration-process.

Normal and disastrous

At this picture 09.09.09 upside right at C schematic is sketched once more, how an extension of aether-movements works. The light-red circle right side represents an area of Free Aether. There many motions swirl to and fro and all over that spot, e.g. as a result of numberless overlays of all crossing radiations. These movements at short tracks are running by speed of light (or some faster, because the light represents only the speed of the signal, the medium by itself might run faster, e.g. the air-particles are moving 1.4 faster than the sound progresses).

The movements of that face become wider, e.g. like marked by the face left side at C. The aether-points do longer ways at tracks more stretched - however they do not fly faster. The short track-sections of the Free Aether are only some 'unravalled' (e.g. like chaotic molecular motion of gas-particles are transferred into an ordered flow). The aether-points move by unchanged speed only at some straighter tracks.

At this surface at C, also a stroke-component (dark-red sector) is sketched. This comes up inevitably e.g. when two circled motions are overlaying. At the one hand the track is stretched (and the aether-point is passing faster this sector), same time however another sector is condensed (and the aether-point is moving slower). As a whole all movements occur with the average of the general speed (of light or some faster). Even all aether is one coherent whole, multiple local motion-pattern are possible. Mostly they come up by that 'cone-like' extensions and these 'stroke-components'.

At this picture right side at the middle at D, a situation is sketched where two neighbouring aether-areas are turning with different speeds. The blue lines point out, how connecting-lines become 'twisted'. Within the gapless aether comes up stress respective it's finally impossible that neighbouring aether-points are mutually passing by. The aether-vortices of material particles well can fly different directions nearby each other, e.g. when two wheels side-by-side are rotating with different speeds. Within the gapless aether however, neighbouring aether-points must keep neighbored directly and all times. Thus an disastrous stress comes up, when previous 'oversized' turning comes up at the centre of the ball-bearing vortex. This speed no longer corresponds to the average speed of movements of Free Aether. That whirlpool no longer shows the necessary asymmetry. Practically no balancing movements are possible to reduce the differences. The result is really a catastrophe - for such ball-bearing machines - or even for a star.

Excursus: Pulsar

The astronomy deals with 5 % of the universe and puts 95 % into a black-box called 'dark-matter or dark-energy'. So it's rather dubious to calculate back in time for millions of years up to a suggested big-bang, in addition assuming universe-wide constant of 'mass-attraction' and same time constant and maximum speed of light. So it seems rather unreliable to believe, e.g. triple sun-masses could collapse to a neutron-star of 20 km diameter and such pulsars could do one revolution during few seconds or even a hundredth second and push off 'jets' into axial direction, millions of kilometer - and beyond speed of light. However, previous consideration could explain these appearances respective a pulsar is a gigantic example for these processes. The gas-particles of a star are compressed by the outside general aether-pressure (and not by mass-attraction). The particles collide frequently and hard collisions result previous 'twisting' of connecting-lines. These stress-situations produce radiations, hitting next particles with their light-speed, so that gas-area is heated-up extremely. Finally the aether can handle the strong tensions only by a general 'liberation-stroke': the star explodes in shape of a supernova.

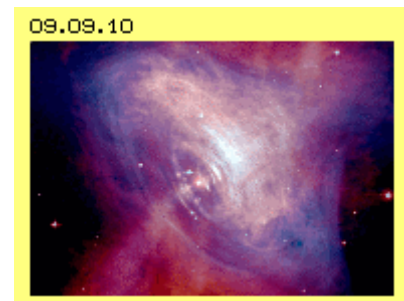

The outside shells of the star are pushed off, sometimes rather concentric, e.g. like this picture 09.09.10 shows. Then, also the counter-pressure of the explosion affects radial concentric inward. The gas-particles become concentrated and their vortices probably could pass over to a plasma. At the shell-shaped focus of the explosion still exists a stroke-component, corresponding to the rotation-speed there. The radius will be some hundred thousand kilometer and one revolution will take some days. If now these stroke-components are shifted concentric inward by the concentric acting explosion-pressure, these 'oversized' turning speeds come up (what's the real process for the theoretic constant of mechanic turning-momentum). At the radius of few kilometer thus can result diverse revolutions each second. At the pole-regions generally exist slower movements - and through these 'weak-spots' finally the 'over-stressed' aether can slacken - by pushing off jets with supra-light-speed.

Controlled System

Some experiments obviously reproduced these disastrous situations. Reports are often talking about step-wise self-acceleration. At previous discussion these processes were based on electrostatic charge of systems. Analogue could react the systems based on rotating permanent magnets. In principle, at first is necessary an ordered aether-swinging (here of a charge, there of manifold magnetic fieldlines), 'heated-up' by overlaying movements (e.g. by revolutions around system-axis and additional revolutions around own axis). At the one hand, these pulsating respective amplified movements are a result of the rotating mechanic parts and 'static' fields, which makes the neighbouring Free Aether resonant co-swinging. At the other hand, the enforced strokes within the aether affect thrust on the material parts of the machine.

Based on this understanding, one should be able to control these processes. At the one hand, a mechanic turning momentum is achieved, i.e. these machines could work as motors. At the other hand, the original static charge is enforced by these processes, so machines could also work as electric generators. Next chapter 'ball-bearing aether-machines' will show some proposals for realization of that principle.